



Airless Spray Technology

Owner's Manual

For professional use only

Do not use this equipment before reading this manual!

840i Airless Sprayer

International Model



Model Number:

High Rider Bare	800-130-CE
High Rider Complete	800-131-CE
Low Rider Bare	800-132-CE
Low Rider Complete	800-133-CE

NOTE: This manual contains important warnings and instructions. Please read and retain for reference.

Table of Contents

Safety Precautions	2
Français	14
Español	16
General Description	4
Operation	4
Setup	4
Preparing to Paint.....	4
Painting	5
Electronic Pressure Control Indicators	5
Pressure Relief Procedure	6
Spraying	6
Spraying Technique	6
Practice	7
Cleanup	7
Cleaning the Spray Tip	7
Maintenance	8
General Repair and Service Notes.....	8
Replacing the Motor Assembly	8
Replacing the Gears	8
Replacing the Transducer.....	9
Replacing the PRIME/SPRAY Valve.....	9
Servicing the Fluid Section	10
Replacing the Filters	11
Troubleshooting	12
Parts Listings	18
Main Assembly.....	18
Drive Assembly	19
Fluid Section Assembly	20
High Rider Cart.....	21
Filter Assembly	21
Siphon Set Assembly (low rider)	22
Low Rider Cart.....	22
Labels	22
PRIME/SPRAY Assembly	23
Electrical Schematic	23
Accessories	23
Warranty	24

Safety Precautions

This manual contains information that must be read and understood before using the equipment. When you come to an area that has one of the following symbols, pay particular attention and make certain to heed the safeguard.



This symbol indicates a potential hazard that may cause serious injury or loss of life. Important safety information will follow.



This symbol indicates a potential hazard to you or to the equipment. Important information that tells how to prevent damage to the equipment or how to avoid causes of minor injuries will follow.

NOTE: Notes give important information which should be given special attention.



Airless units develop extremely high spraying pressures.



- Never put your fingers, hands or any other parts of the body into the spray jet.
- Never point the spray gun at yourself or anybody else.
- Never use the spray gun without the safety guard.

Attention! Danger of injury by injection!

In case of injury to skin caused by coating materials or solvents consult a doctor immediately. Inform the doctor of the type of coating material or cleaning agent with which the injury was caused.

The operating instructions state that the following points must always be observed before starting up:

1. Faulty units should not be used.
2. Secure spray gun using the safety catch on the trigger.
3. Ensure that the unit is properly earthed.
4. Check the permissible operating pressures.
5. Check all connections for leaks.

The instructions regarding regular cleaning and maintenance of the unit must be strictly observed.

Before any work is done on the unit or for every break in work the following rules must be observed:

1. Release the pressure from the spray gun and hose.
2. Secure the spray gun using the safety catch on the trigger.
3. Turn off the motor.

Be safety-conscious!

All local regulations in force must be observed.

In order to ensure safe operation of the airless systems the safety regulations listed below must be followed:

1. In order to avoid dangers, read the operating instructions carefully and follow the instructions laid down in them.
2. Do not use materials with a flash point below 21°C (70°F).
3. The use of this unit is prohibited in workshops which are covered under the explosion prevention regulations.
4. Never spray near sources of ignition; e.g. open flames, cigarettes — also cigars and pipes are sources of ignition — sparks, hot wires and hot surfaces, etc.
5. Attention! Danger of injury by injection!

Never point the spray gun at yourself or anyone else.

Never put your fingers or hands into the spray jet. The very high spraying pressures can cause very serious injuries. Never use the spray gun without the safety guard.



When installing and removing the tip and during breaks in work the spray gun must always be secured, so that it cannot be activated.

6. Wear respiratory equipment when spraying. The operator must be provided with a protective mask.

In order to prevent work related illness, the manufacturer's regulations for the materials, solvents, and cleaning agents used must be observed when preparing, working with and cleaning the unit. Protective clothing, gloves and, in certain cases, protective skin cream are necessary to protect the skin.

7. The spray gun and high pressure hose between the unit and spray gun must be of a sufficient standard for the pressure produced in the unit.

The permissible operating pressure for the high-pressure hose, the manufacturer and date of manufacture must be indicated by a permanent identification marking on the hose. Furthermore, it must be constructed so that the electrical resistance between the connections to the unit and the spray gun is equal to or less than one megohm.

8. Under certain conditions the flow speed can cause an electrostatic charge on the unit. This could cause sparks or flames on discharging. It is, therefore, important that the unit is always earthed over the electrical installation. The contact should be made using a shockproof socket earthed in accordance with the regulations.

9. Attention! Please observe the following when working inside and outside:
No solvent gasses should be carried to the unit. No solvent gasses should form near the unit. Set up the unit on the opposite side to the object being sprayed. When spraying outdoors, take the wind direction into account. When spraying indoors there must be sufficient ventilation to ensure that the solvent gasses are carried away. A minimum distance of 6.1m (20') must be observed between the unit and object being sprayed.
10. Extraction equipment should be installed by the user in accordance with the local regulations.
11. The objects being sprayed must be earthed.
12. When cleaning the unit, solvent should never be sprayed into a container with only a small opening (bunghole). An explosive gas/air mixture is likely to form. The container must be earthed.
13. Cleaning the unit.
A harsh jet should never be used to spray the unit. In particular a high-pressure cleaner or high-pressure steam cleaner should never be used. There is a danger that water will penetrate into the unit and cause a short-circuit.
14. Pulling the trigger causes a recoil force to the hand that is holding the spray gun.
The recoil force of the spray gun is particularly powerful when the tip has been removed and a high pressure has been set on the airless high-pressure pump. Therefore, when cleaning without tip set the pressure control valve to the lowest pressure.
15. The mains plug should always be disconnected from the socket when work is being carried out on the electrical components.
16. Work or repairs should only be carried out on electrical equipment by a trained electrician, even if the work is described in the operating instructions. No liability will be accepted for incorrectly installed electrics.
17. Positioning when the ground is uneven.
The front of the unit must point downward so that the machine does not slip away.

HAZARD: INJECTION INJURY - A high pressure stream of paint produced by this equipment can pierce the skin and underlying tissues, leading to serious injury and possible amputation.

DO NOT TREAT AN INJECTION INJURY AS A SIMPLE CUT! Injection can lead to amputation. See a physician immediately.

PREVENTION:

- The maximum operating range of the unit is 228 BAR (3300 PSI) fluid pressure.
- NEVER aim the gun at any part of the body.
- NEVER allow any part of the body to come in contact with the fluid stream. DO NOT come in contact with a fluid stream created by a leak in the fluid hose.
- NEVER put your hand in front of the gun. Gloves will not provide protection against an injection injury.
- ALWAYS lock the gun trigger, shut the fluid pump off and release all pressure before servicing, cleaning the tip guard, changing tips, or leaving unattended. Pressure will not be released by turning off the engine. The PRIME/SPRAY knob must be turned to PRIME to relieve the pressure. Refer to the PRESSURE RELIEF PROCEDURE described in this manual.
- The tip guard must always be in place while spraying. The tip guard provides some protection against injection injuries but is mainly a warning device.
- ALWAYS remove the spray tip before flushing or cleaning the system.
- The paint hose can develop leaks from wear, kinking and abuse. A leak is capable of injecting material into the skin. Inspect the paint hose before each use.

NOTE TO PHYSICIAN:

Injection into the skin is a traumatic injury. It is important to treat the injury surgically as soon as possible. DO NOT delay treatment to research toxicity. Toxicity is a concern with some coatings injected directly into the blood stream. Consultation with a plastic surgeon or reconstructive hand surgeon may be advisable.

HAZARD: EXPLOSION OR FIRE - Solvent and paint fumes can explode or ignite, causing property damage and/or severe injury.

PREVENTION:

- Fire extinguishing equipment must be present and in good working order.
- Use only conductive or earthed high pressure fluid hoses for airless applications. Be sure that the gun is earthed properly through hose connections.
- The pump must be connected to an earthed object. Use the green earthing wire to connect the pump to a water pipe, steel beam, or other electrically earthed surface.
- When flushing equipment use the lowest possible pressure.

HAZARD: EXPLOSION HAZARD DUE TO INCOMPATIBLE MATERIALS- May cause property damage or severe injury.

PREVENTION:

- Do not use bleach.
- Do not use halogenated hydrocarbon solvents such as methylene chloride and 1,1,1 - trichloroethane. They are not compatible with aluminum and may cause an explosion. If you are unsure of a material's compatibility with aluminum, contact your coating's supplier.

HAZARD: GENERAL - May cause property damage or severe injury.

PREVENTION:

- This high pressure airless pump is designed to be used with manufacturer authorized parts only. When using this pump with parts that do not comply with the minimum specifications and safety devices of the pump manufacturer, the user assumes all risks and liabilities.
- Before each use, check all hoses for cuts, leaks, abrasion or bulging of cover, as well as damage or movement of couplings. If any of these conditions exist, replace the hose immediately. Never repair a paint hose. Replace it with another earthed hose.
- Wear protective eyewear.
- Do not spray on windy days.

Earthing Instructions

This product must be earthed. In the event of an electrical short circuit, earthing reduces the risk of electric shock by providing an escape wire for the electric current. This product is equipped with a cord having an earthing wire with an appropriate earthing plug. The plug must be plugged into an outlet that is properly installed and earthed in accordance with all local codes and ordinances.

DANGER — Improper installation of the earthing plug can result in a risk of electric shock.

If repair or replacement of the cord or plug is necessary, do not connect the green earthing wire to either flat blade terminal. The wire with insulation having a green outer surface with or without yellow stripes is the earthing wire and must be connected to the earthing pin.

Check with a qualified electrician or serviceman if the earthing instructions are not completely understood, or if you are in doubt as to whether the product is properly earthed. Do not modify the plug provided. If the plug will not fit the outlet, have the proper outlet installed by a qualified electrician.

General Description

This airless sprayer is a precision power tool used for spraying many types of materials. Read and follow this instruction manual carefully for proper operating instructions, maintenance, and safety information.

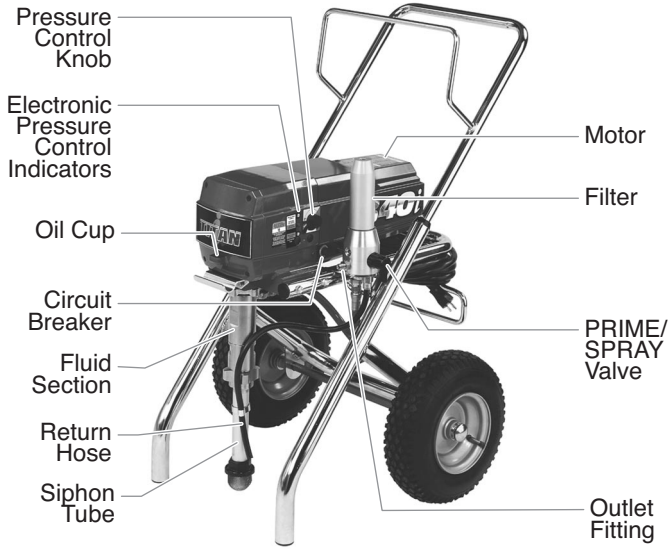

Operation

WARNING

This equipment produces a fluid stream at extremely high pressure. Read and understand the warnings in the Safety Precautions section at the front of this manual before operating this equipment.

Setup

Perform the following procedure before plugging in the power cord of an electric unit.

1. Ensure that the siphon tube/siphon set and the return hose are attached and secure.
2. Using a wrench, attach a minimum of 15m (50') x 10mm (1/4") nylon airless spray hose to the unit. Tighten securely.
3. Attach an airless spray gun to the spray hose. Using two wrenches (one on the gun and one on the hose), tighten securely.

NOTE: Do not attach the tip to the spray gun yet. Remove the tip if it is already attached.

WARNING

Make sure all airless hoses and spray guns are electrically grounded and rated for at least 228 bar (3300 psi) fluid pressure.

4. Make sure the pressure control knob is in its OFF position in the black zone.
5. Fill the oil cup with 15g (one tablespoon) of piston seal lubricant (Piston Lube).

CAUTION

Never operate unit for more than ten seconds without fluid. Operating this unit without fluid will cause unnecessary wear to the packings.

6. Make sure the electrical service is correct for the unit.
7. Plug the power cord into a properly grounded outlet at least 7.6m (25') from the spray area.

CAUTION

Always use a minimum 12 gauge, three-wire extension cord with a grounded plug. Never remove the third prong or use an adapter.

Preparing a New Sprayer

If this unit is new, it is shipped with test fluid in the fluid section to prevent corrosion during shipment and storage. This fluid must be thoroughly cleaned out of the system with mineral spirits before you begin spraying.

CAUTION

Always keep the trigger lock on the spray gun in the locked position while preparing the system.

1. Place the siphon tube into a container of mineral spirits.
2. Place the return hose into a metal waste container.
3. Move the PRIME/SPRAY valve down to the PRIME position.
4. Turn the unit on and set the pressure to minimum by turning the pressure control knob to the "Min PSI" setting in the yellow zone.

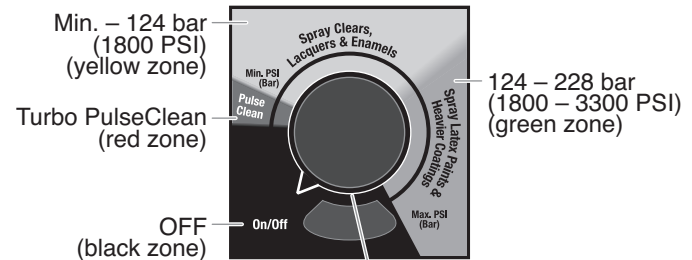

5. Allow the sprayer to run for 15–30 seconds to flush the test fluid out through the return hose and into the waste container.
6. Turn the unit off by moving the pressure control knob to the OFF position in the black zone.

Preparing to Paint

Before painting, it is important to make sure that the fluid in the system is compatible with the paint that is going to be used.

NOTE: Incompatible fluids and paint may cause the valves to become stuck closed, which would require disassembly and cleaning of the sprayer's fluid section.

CAUTION

Always keep the trigger lock on the spray gun in the locked position while preparing the system.

1. Place the siphon tube into a container of the appropriate solvent. Examples of the appropriate solvent are water for latex paint or mineral spirits for oil-based paints.
2. Place the return hose into a metal waste container.
3. Move the PRIME/SPRAY valve down to the PRIME position.
4. Turn the unit on and set the pressure to minimum by turning the pressure control knob to the "Min PSI" setting in the yellow zone.
5. Allow the sprayer to run for 15–30 seconds to flush the old solvent out through the return hose and into the metal waste container.
6. Turn the unit off by moving the pressure control knob to the OFF position in the black zone.

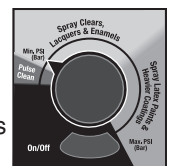

NOTE: Make sure that the spray gun does not have a tip or tip guard installed.

7. Move the PRIME/SPRAY valve up to the SPRAY position.
8. Turn the unit on and set the pressure to minimum by turning the pressure control knob to the “Min PSI” setting in the yellow zone.
9. Unlock the gun by turning the gun trigger lock to the unlocked position.

⚠ WARNING

Ground the gun by holding it against the edge of the metal container while flushing. Failure to do so may lead to a static electric discharge, which may cause a fire.



10. Trigger the gun into the metal waste container until the old solvent is gone and fresh solvent is coming out of the gun.
11. Lock the gun by turning the gun trigger lock to the locked position.
12. Set down the gun and increase the pressure by turning the pressure control knob slowly clockwise into the green zone. Stop when the pressure indicator is solid green.
13. Check the entire system for leaks. If leaks occur, turn off the unit and follow the “Pressure Relief Procedure” in this manual before tightening any fittings or hoses.
14. Follow the “Pressure Relief Procedure” in this manual before changing from solvent to paint.

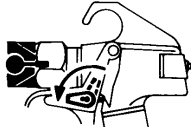

Trigger lock in locked position.

⚠ WARNING

Be sure to follow the pressure relief procedure when shutting the unit down for any purpose, including servicing or adjusting any part of the spray system, changing or cleaning spray tips, or preparing for cleanup.

Painting

1. Place the siphon tube into a container of paint.
2. Place the return hose into a metal waste container.
3. Move the PRIME/SPRAY valve down to the PRIME position.
4. Turn the unit on and set the pressure to minimum by turning the pressure control knob to the “Min PSI” setting in the yellow zone.
5. Allow the sprayer to run until paint is coming through the return hose into the metal waste container.
6. Turn the unit off by moving the pressure control knob to the OFF position in the black zone.
7. Remove the return hose from the waste container and place it in its operating position above the container of paint.
8. Move the PRIME/SPRAY valve up to the SPRAY position.
9. Turn the unit on and set the pressure to minimum by turning the pressure control knob to the “Min PSI” setting in the yellow zone.
10. Unlock the gun by turning the gun trigger lock to the unlocked position.



⚠ WARNING

Ground the gun by holding it against the edge of the metal container while flushing. Failure to do so may lead to a static electric discharge, which may cause a fire.



11. Trigger the gun into the metal waste container until all air and solvent is flushed from the spray hose and paint is flowing freely from the gun.

12. Lock the gun by turning the gun trigger lock to the locked position.
13. Turn the unit off by moving the pressure control knob to the OFF position in the black zone.
14. Attach tip guard and tip to the gun as instructed by the tip guard or tip manuals.

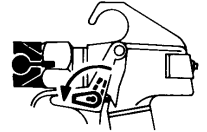

Trigger lock in locked position.

⚠ WARNING

POSSIBLE INJECTION HAZARD. Do not spray without the tip guard in place. Never trigger the gun unless the tip is in either the spray or the unclog position. Always engage the gun trigger lock before removing, replacing or cleaning tip.

15. Turn the unit on and set the pressure to minimum by turning the pressure control knob to the “Min PSI” setting in the yellow zone.
16. Increase the pressure by turning the pressure control knob slowly clockwise toward the green zone and test the spray pattern on a piece of cardboard. Adjust the pressure control knob until the spray from the gun is completely atomized.

NOTE: Turning the pressure up higher than needed to atomize the paint will cause premature tip wear and additional overspray.

Electronic Pressure Control Indicators

The following is a description of the electronic pressure control indicators.

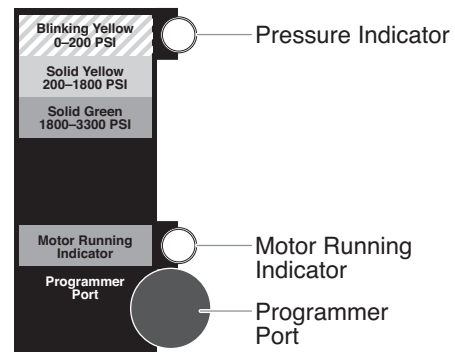

Pressure Indicator

The pressure indicator shows the current operating pressure of the sprayer. It has three different indications: blinking yellow, solid yellow, and solid green.

Blinking Yellow

When the pressure indicator is blinking yellow, the sprayer is operating between 0 and 14 bar (200 PSI). A blinking yellow pressure indicator means:

- The sprayer is plugged in and turned “ON”.
- The sprayer is at priming pressure (little or no pressure).
- It is safe to move the PRIME/SPRAY valve between positions.
- It is safe to change or replace the spray tip (refer to gun manual for tip replacement instructions).

NOTE: If the pressure indicator begins blinking yellow when the pressure control knob is set at a higher pressure and the PRIME/SPRAY valve is in the SPRAY position, either the spray tip is worn, there is a leak, or the sprayer is in need of service/repair.

Solid Yellow

When the pressure indicator is solid yellow, the sprayer is operating between 14 and 124 bar (200 and 1800 PSI). A solid yellow pressure indicator means:

- The sprayer is at the proper pressure setting for spraying stain, lacquer, varnish, and multi-colors.
- If the pressure indicator goes to solid yellow when the pressure is set so that it starts at solid green, it indicates one of the following:
 - a. Tip Wear Indicator — when spraying with latex or at high pressure the solid yellow appears. This means the tip is worn and needs to be replaced.
 - b. Tip Too Large — when a tip that is too large for the sprayer is put in the gun, the pressure indicator will turn from solid green to solid yellow.
 - c. Fluid Section Wear — if a solid yellow pressure indicator appears when using a new tip and the pressure is set at maximum, service may be required (worn packings, worn piston, stuck valve, etc...).

Solid Green

When the pressure indicator is solid green, the sprayer is operating between 124 and 228 bar (1800 and 3300 PSI). A solid green pressure indicator means:

- The sprayer is at the proper pressure setting for spraying oil-based and latex house paints.
- The sprayer is operating at peak performance at a high pressure setting.

Motor Running Indicator

The Motor Running indicator is on when the motor is commanded to run. This indicator is used by service centers to troubleshoot motor problems.

Pressure Relief Procedure

⚠WARNING

Be sure to follow the pressure relief procedure when shutting the unit down for any purpose, including servicing or adjusting any part of the spray system, changing or cleaning spray tips, or preparing for cleanup.

1. Lock the gun by turning the gun trigger lock to the locked position.
2. Turn the pressure control knob counterclockwise to its OFF position in the black zone.
3. Unlock the gun by turning the gun trigger lock to the unlocked position.
4. Hold the metal part of the gun firmly to the side of a metal container to ground the gun and avoid a build up of static electricity.
5. Trigger the gun to remove any pressure that may still be in the hose.
6. Lock the gun by turning the gun trigger lock to the locked position.
7. Move the PRIME/SPRAY valve down to the PRIME position.

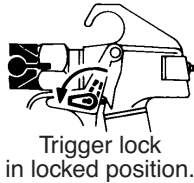

Spraying

NOTE: When spraying block fillers, mastics, or high solid coatings, remove the gun filter and the high pressure filter.

⚠WARNING

POSSIBLE INJECTION HAZARD. Do not spray without the tip guard in place. Never trigger the gun unless the tip is in either the spray or the unclog position. Always engage the gun trigger lock before removing, replacing, or cleaning tip.

Spraying Technique

The following techniques, if followed, will assure professional painting results.

Hold the gun perpendicular to the surface and always at equal distance from the surface. Depending on the type of material, surface, or desired spray pattern, the gun should be held at a distance of 30 to 35 cm (12 to 14 inches).

Move the gun either across or up and down the surface at a steady rate. Moving the gun at a consistent speed conserves material and provides even coverage. The correct spraying speed allows a full, wet coat of paint to be applied without runs or sags.

Holding the gun closer to the surface deposits more paint on the surface and produces a narrower spray pattern. Holding the gun farther from the surface produces a thinner coat and wider spray pattern. If runs, sags, or excessive paint occur, change to a spray tip with a smaller orifice. If there is an insufficient amount of paint on the surface or you desire to spray faster, a larger orifice tip should be selected.

Maintain uniform spray stroke action. Spray alternately from left to right and right to left. Begin movement of the gun before the trigger is pulled.

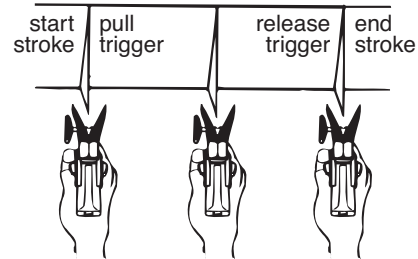

Avoid arcing or holding the gun at an angle. This will result in an uneven finish.

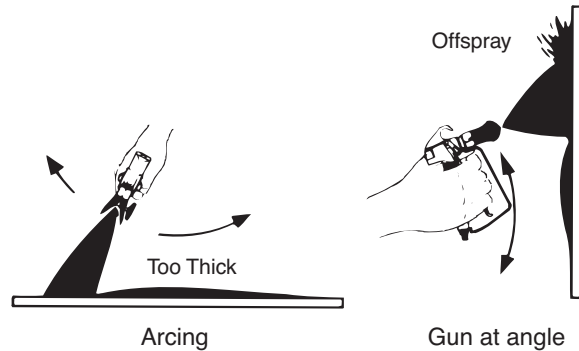

Proper lapping (overlap of spray pattern) is essential to an even finish. Lap each stroke. If you are spraying horizontally, aim at the bottom edge of the preceding stroke, so as to lap the previous pattern by 50%.

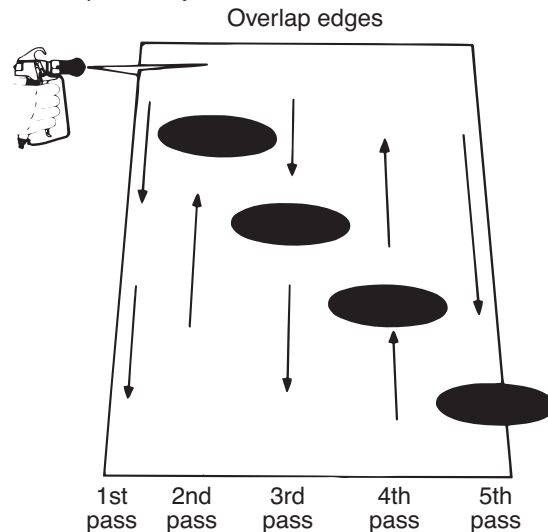

For corners and edges, split the center of the spray pattern on the corner or edge and spray vertically so that both adjoining sections receive approximately even amounts of paint.

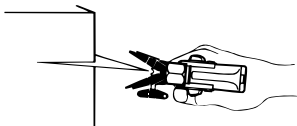

When spraying with a shield, hold it firmly against the surface. Angle the spray gun slightly away from the shield and toward the surface. This will prevent paint from being forced underneath.

Shrubs next to houses should be tied back and covered with a canvas cloth. The cloth should be removed as soon as possible. Titan gun extensions are extremely helpful in these situations. Nearby objects such as automobiles, outdoor furniture, etc. should be moved or covered whenever in the vicinity of a spray job. Be careful of any other surrounding objects that could be damaged by overspray.

Practice

1. Be sure that the paint hose is free of kinks and clear of objects with sharp cutting edges.
2. Turn the pressure control knob counterclockwise to its lowest setting.
3. Turn the PRIME/SPRAY valve up to its SPRAY position.
4. Turn the pressure control knob clockwise to its highest setting. The paint hose should stiffen as paint begins to flow through it.
5. Unlock the gun trigger lock.
6. Trigger the spray gun to bleed air out of the hose.
7. When paint reaches the spray tip, spray a test area to check the spray pattern.
8. Use the lowest pressure setting necessary to get a good spray pattern. If the pressure is set too high, the spray pattern will be too light. If the pressure is set too low, tailing will appear or the paint will spatter out in gobs rather than in a fine spray.

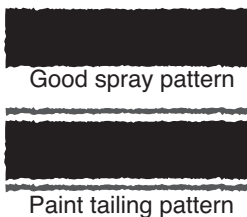

Cleanup

⚠ WARNING

Special cleanup instructions for use with flammable solvents:

- Always flush spray gun preferably outside and at least one hose length from spray pump.
- If collecting flushed solvents in a one gallon metal container, place it into an empty five gallon container, then flush solvents.
- Area must be free of flammable vapors.
- Follow all cleanup instructions.

⚠ CAUTION

The sprayer, hose, and gun should be cleaned thoroughly after daily use. Failure to do so permits material to build up, seriously affecting the performance of the unit.

⚠ WARNING

Always spray at minimum pressure with the gun nozzle tip removed when using mineral spirits or any other solvent to clean the sprayer, hose, or gun. Static electricity buildup may result in a fire or explosion in the presence of flammable vapors.

1. Follow the "Pressure Relief Procedure" found in the Operation section of this manual.
2. Remove the gun tip and tip guard and clean with a brush using the appropriate solvent.

3. Place the siphon tube into a container of the appropriate solvent. Examples of the appropriate solvent are water for latex paint or mineral spirits for oil-based paints.
4. Place the return hose into a metal waste container.
5. Move the PRIME/SPRAY valve down to its PRIME position.
6. Turn the unit on and set the pressure to Turbo PulseClean by turning the pressure control knob to its CLEAN position in the red zone.
7. Allow the solvent to circulate through the unit and flush the paint out of the return hose into the metal waste container.
8. Turn the unit off by moving the pressure control knob to the OFF position in the black zone.
9. Move the PRIME/SPRAY valve up to its SPRAY position.
10. Turn the unit on and set the pressure to Turbo PulseClean by turning the pressure control knob to its CLEAN position in the red zone.



⚠ WARNING

Ground the gun by holding it against the edge of the metal container while flushing. Failure to do so may lead to a static electric discharge, which may cause a fire.



11. Trigger the gun into the metal waste container until the paint is flushed out of the hose and solvent is coming out of the gun.
12. Continue to trigger the spray gun into the waste container until the solvent coming out of the gun is clean.

NOTE: For long-term or cold weather storage, pump mineral spirits through the entire system.

For short-term storage when using latex paint, pump water mixed with Titan Liquid Shield Plus through the entire system (see the Accessories section of this manual for part number).

13. Follow the "Pressure Relief Procedure" found in the Operation section of this manual.
14. Unplug the unit and store in a clean, dry area.

⚠ CAUTION

Do not store the unit under pressure.

Cleaning the Spray Tip

1. Flush the gun with solvent immediately after the work is completed.
2. Oil the retractor pins to prevent them from seizing up.

Should the spray tip become clogged, reverse the spray tip with the lever and pull the trigger. Once the obstruction comes out of the spray tip, release the trigger, reverse the spray tip back to the spray pattern setting, and resume spraying.

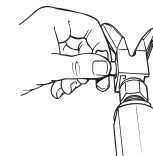

⚠ WARNING

Do not attempt to clean the tip with your finger. Do not use a needle or other sharp pointed instrument to clean the tip. The hard tungsten carbide is brittle and can be chipped.

Maintenance

⚠ WARNING

Before proceeding, follow the Pressure Relief Procedure outlined previously in this manual. Additionally, follow all other warnings to reduce the risk of an injection injury, injury from moving parts or electric shock. Always unplug the sprayer before servicing!

General Repair and Service Notes

The following tools are needed when repairing this sprayer:

Phillips Screwdriver	3/8" Hex Wrench
Needle Nose Pliers	5/16" Hex Wrench
Adjustable Wrench	1/4" Hex Wrench
Rubber Mallet	3/16" Hex Wrench
Flat-blade Screwdriver	5/32" Hex Wrench

1. Before repairing any part of the sprayer, read the instructions carefully, including all warnings.

⚠ CAUTION

Never pull on a wire to disconnect it. Pulling on a wire could loosen the connector from the wire.

2. Test your repair before regular operation of the sprayer to be sure that the problem is corrected. If the sprayer does not operate properly, review the repair procedure to determine if everything was done correctly. Refer to the Troubleshooting Charts to help identify other possible problems.
3. Make certain that the service area is well ventilated in case solvents are used during cleaning. Always wear protective eyewear while servicing. Additional protective equipment may be required depending on the type of cleaning solvent. Always contact the supplier of solvents for recommendations.
4. If you have any further questions concerning your TITAN Airless Sprayer, call TITAN:

Customer Service (U.S.)	1-800-526-5362
Fax	1-800-528-4826
Customer Service (Canada)	1-800-565-8665
Fax	1-905-856-8496
Customer Service (International)	1-201-337-1240
Fax	1-201-405-7449

Replacing the Motor Assembly (with Electronic Control)

⚠ WARNING

Electrostatic discharge (ESD) potential could cause damage to electronic control. Use Titan ESD wrist strap P/N 700-1037 or equivalent when working on electronic control with electronic cover removed.

1. Perform the Pressure Relief Procedure, and unplug the unit.
2. Turn the pressure control knob to the CLEAN position in the red zone to discharge any stored electricity.
3. Loosen and remove the four motor shroud screws. Remove the motor shroud.
4. Release the tie wrap on the top of the baffle assembly and slip the baffle assembly down off of the motor.
5. Loosen and remove the three electronic cover screws. Lift the electronic cover off of the electronic control assembly on the motor.

6. At the electronic control assembly:
 - a. Disconnect the white wire coming from the power cord and the white wire coming from the relay.
 - b. Disconnect the three wires coming from the potentiometer.
 - c. Disconnect the seven wires coming from the indicator lights assembly.
7. Loosen and remove the three motor mounting screws.
8. Pull the motor out of the gearbox housing.
9. With the motor removed, inspect the gears in the gearbox housing for damage or excessive wear. Replace the gears, if necessary.
10. Install the new motor into the gearbox housing. Make sure the housing gasket is positioned properly.
11. Secure the motor with the three motor mounting screws.
12. Reconnect the wires to the electronic control assembly (refer to the electrical schematic in the Parts List section of this manual).
13. Position the electronic cover over the electronic control assembly. Secure the electronic cover with the three electronic cover screws.

NOTE: Use only Titan electronic cover screws to secure the electronic cover (see Drive Assembly parts list). Use of any other screws may damage the electronic control assembly.

14. Slip the baffle assembly up and around the motor. Secure the baffle assembly with the tie wrap.
15. Slide the motor shroud over the motor. Make sure the shroud gasket is positioned properly.
16. Secure the motor shroud with the four motor shroud screws.

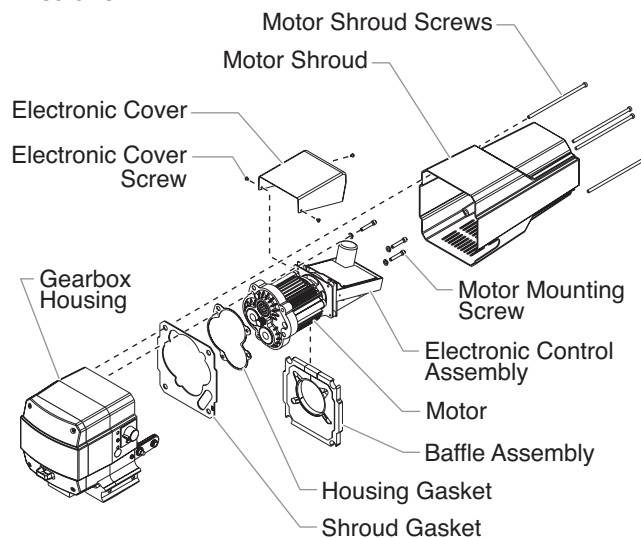

Replacing the Gears

1. Perform the Pressure Relief Procedure, and unplug the unit.
2. Turn the pressure control knob to the CLEAN position in the red zone to discharge any stored electricity.
3. Loosen and remove the four motor shroud screws. Remove the motor shroud.
4. Release the tie wrap on the top of the baffle assembly and slip the baffle assembly down off of the motor.
5. Loosen and remove the three electronic cover screws. Lift the electronic cover off of the electronic control assembly on the motor.
6. At the electronic control assembly:
 - a. Disconnect the white wire coming from the power cord and the white wire coming from the relay.
 - b. Disconnect the three wires coming from the potentiometer.
 - c. Disconnect the seven wires coming from the indicator lights assembly.

7. Loosen and remove the three motor mounting screws.
8. Pull the motor out of the gearbox housing.
9. Inspect the armature gear on the end of the motor for damage or excessive wear. If this gear is completely worn out, replace the front end bell assembly.
10. Remove and inspect the 1st stage gear and 2nd stage gear assemblies for damage or excessive wear. Replace, if necessary.
11. Remove and inspect the front gear box assembly for damage or excessive wear. If damaged or worn, replace the front gear box assembly.

NOTE: Clean and refill the gear box cavity up to the rear face of each gear with Lubriplate (P/N 314-171).

12. Install the motor into the gearbox housing. Make sure the housing gasket is positioned properly.
13. Secure the motor with the three motor mounting screws.
14. Reconnect the wires to the electronic control assembly (refer to the electrical schematic in the Parts List section of this manual).
15. Position the electronic cover over the electronic control assembly. Secure the electronic cover with the three electronic cover screws.
16. Slip the baffle assembly up and around the motor. Secure the baffle assembly with the tie wrap.
17. Slide the motor shroud over the motor. Make sure the shroud gasket is positioned properly.
18. Secure the motor shroud with the four motor shroud screws.

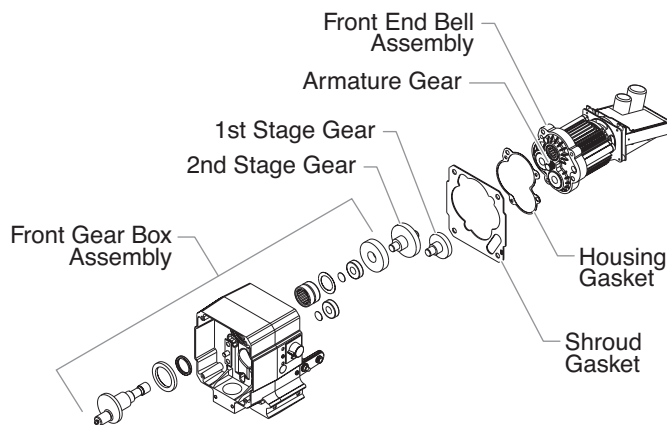

Replacing the Transducer

1. Perform the Pressure Relief Procedure, and unplug the unit.
2. Turn the pressure control knob to the CLEAN position in the red zone to discharge any stored electricity.
3. Loosen and remove the four motor shroud screws. Remove the motor shroud.
4. At the electronic control assembly, disconnect the black wire coming from the transducer.
5. Pull the grommet out of the mounting plate and slide it up the shaft of the transducer until it is clear of the mounting plate.
6. Using a wrench, loosen and remove the transducer from the filter housing. Carefully thread the transducer wire out through the mounting plate.
7. Slide the grommet off of the old transducer and onto the new transducer.
8. Thread the new transducer wire through the mounting plate and up to the electronic control assembly.
9. Thread the new transducer into the filter housing and tighten securely with a wrench.

NOTE: Make sure the o-ring on the transducer is in place before threading the transducer into the filter housing.

10. Push the grommet into the mounting plate.
11. Connect the transducer wire to the electronic control assembly (refer to the electrical schematic in the Parts List section of this manual).
12. Slide the motor shroud over the motor. Make sure the shroud gasket is positioned properly.
13. Secure the motor shroud with the four motor shroud screws.

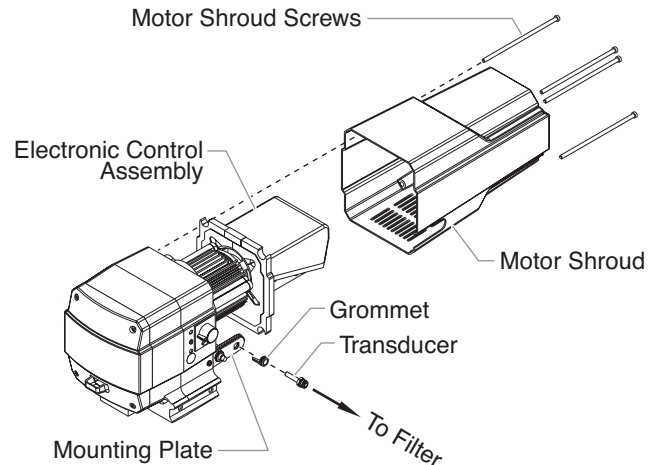

Replacing the PRIME/SPRAY Valve

Perform the following procedure using PRIME/SPRAY valve replacement kit P/N 800-915.

1. Push the groove pin out of the valve handle.
2. Remove the valve handle and the cam base.
3. Using a wrench, loosen and remove the valve housing assembly.
4. Make sure the gasket is in place and thread the new valve housing assembly into the filter block. Tighten securely with a wrench.
5. Place the cam base over the valve housing assembly. Lubricate the cam base with grease and line up the cam with the filter block using the dowel pin.
6. Line up the hole on the valve stem with the hole in the valve handle.
7. Insert the groove pin into the valve handle and through the valve stem to secure the valve handle in position.

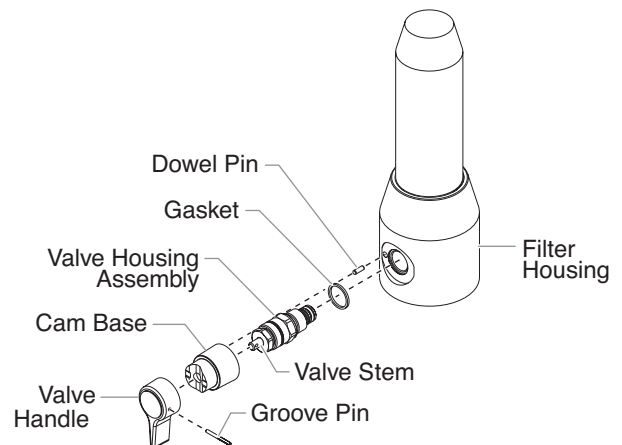

Servicing the Fluid Section

Use the following procedures to service the valves and repack the fluid section. Perform the following steps before performing any maintenance on the fluid section.

1. Loosen and remove the four front cover screws. Remove the front cover.
2. Position the crankshaft/slider assembly at the bottom, dead-center of its stroke so that the connecting pin and retaining ring are visible below the slider assembly. This is done by turning the sprayer on and off in short bursts until the connecting pin is visible below the slider housing.
3. Turn off and unplug the unit.

WARNING

Before proceeding, follow the Pressure Relief Procedure outlined previously in this manual. Additionally, follow all other warnings to reduce the risk of an injection injury, injury from moving parts or electric shock. Always unplug the sprayer before servicing!

4. Remove the return hose from the clamp on the siphon tube.
5. Unscrew the siphon tube/siphon set from the foot valve.
6. Loosen and remove the high-pressure hose from the nipple on the back of the upper housing of the fluid section.

Servicing the Valves

The design of the fluid section allows access to the foot valve and seat as well as the outlet valve and seat without completely disassembling the fluid section. It is possible that the valves may not seat properly because of debris stuck in the foot valve seat or outlet valve seat. Use the following instructions to clean the valves and reverse or replace the seats.

1. Loosen and remove the foot valve housing from the lower housing.
2. Clean out any debris in the foot valve housing and examine the housing and the foot valve seat. If the seat is damaged, reverse or replace the seat.
3. Using two wrenches, hold the upper housing at the wrench flats with one wrench and loosen the lower housing with the other. Remove the lower housing.
4. Using a 3/4" wrench, loosen and remove the outlet valve retainer from the piston rod.

NOTE: Always service the outlet valve with the piston rod attached to the pump. This will prevent the piston rod from rotating during disassembly of the outlet valve.

5. Clean out any debris and examine the retainer and outlet valve seat. If the seat is damaged, reverse or replace the seat.
6. Remove, clean, and inspect the outlet valve cage and outlet valve ball. Replace if they are worn or damaged.
7. Reassemble the valves by reversing the steps above.

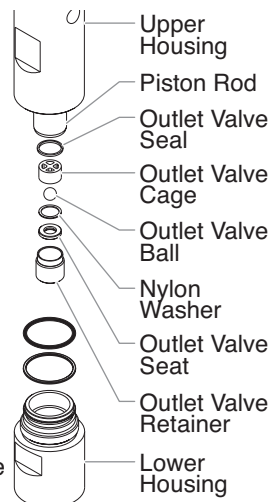
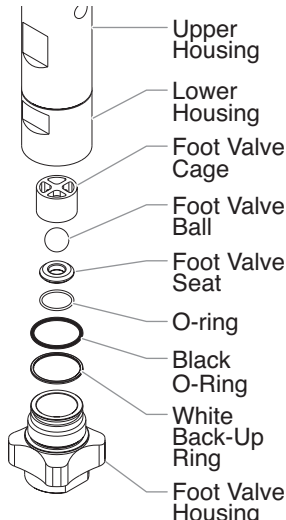

NOTE: During reassembly, make sure the black o-rings and the white back-up rings between the upper housing and lower housing as well as between the lower housing and the foot valve housing are lubricated with grease and in position.

Repacking the Fluid Section

1. Remove the foot valve assembly and the lower housing using the steps in the "Servicing the Valves" procedure above.

NOTE: The outlet valve does not need to be disassembled from the piston rod for this procedure.

2. Slide the retaining ring up on the slider assembly to expose the connecting pin.
3. Push the connecting pin back through the slider assembly and piston. The connecting pin will fall into a recessed area of the gear box housing where it can be retrieved.
4. Tap the knock-off nut with a soft hammer so that it turns counterclockwise and loosens.
5. Turn the fluid section counterclockwise to remove it from the gear box housing.
6. Place the upper housing upright in a vise by clamping on the wrench flats.

NOTE: Do not over-tighten the vise. Damage to the upper housing may occur.

7. Using a wrench, remove the upper seal retainer.
8. Slide the piston rod out through the bottom of the upper housing.
9. Inspect the piston rod for wear and replace if necessary.
10. Remove the upper and lower packings from the upper housing.

NOTE: Be careful not to scratch, score, or otherwise damage the upper housing during removal of the packings.

11. Clean the upper housing. Inspect the upper housing for damage and replace if necessary.
12. Locate the new upper and lower packings and remove the pre-form tools. Save the upper packing pre-form tool for use as the piston insertion tool later in this procedure.

NOTE: The factory-installed packings are black in color. The replacement packings in the packing replacement kit are white. Do not remove the pre-form tools from the upper and lower packings until immediately before they are installed into the upper housing.

13. Pack the areas between the packing lips with grease. Lubricate the o-rings on the exterior of the packings with grease.
14. Insert the upper packing into the top of the upper housing with the raised lip on the packing facing down.

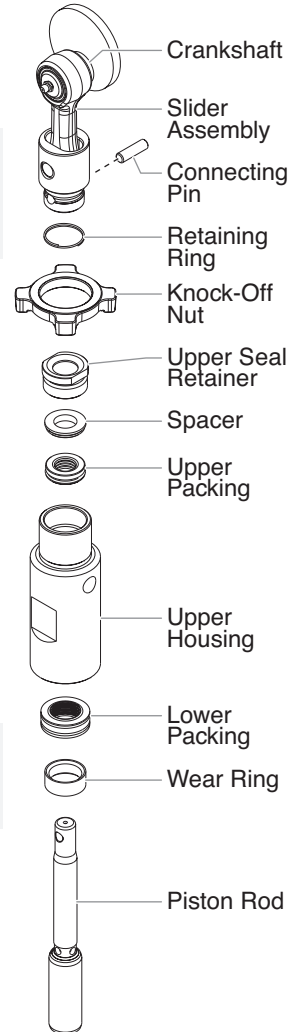

Install upper packing with raised lip facing down.



15. Insert the spacer on top of the upper packing.
16. Thread the upper seal retainer into the upper housing and torque to 25-30 ft. lbs.
17. Insert the lower packing partially into the bottom of the upper housing so that the side that has the o-ring closest to the face of the packing faces up.

Install lower packing with the side that has the o-ring closest to the face of the packing facing up.
18. Push the lower packing into position using the lower packing insertion tool (see Fluid Section Assembly parts list for lower packing insertion tool P/N).

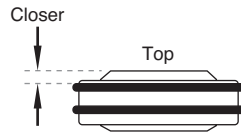

NOTE: Coat the piston insertion tool (i.e., upper packing pre-form tool) and the piston rod with grease before inserting them into the pump block.

19. Place the piston insertion tool over the top of the piston rod.
20. Insert the piston rod into the bottom of the upper housing, through the lower packing, through the upper packing, and out through the upper seal retainer.

NOTE: When repacking the fluid section, make sure the raised lip on the bottom of the lower packing is fully outside the packing around the piston rod after insertion of the piston rod.

21. Remove the piston insertion tool from the top of the piston rod.
22. Turn the knock-off nut counterclockwise until it is flush against the upper housing.
23. Lubricate the threads on the upper housing with anti-seize compound. Remove the upper housing from the vise.
24. Thread the upper housing into the gear box housing, turning clockwise. When the connecting pin hole on the piston rod lines up with the hole in the slider assembly, insert the connecting pin.
25. Slide the retaining ring down over the connecting pin.
26. Continue to turn the upper housing clockwise until the knock-off nut is flush against the gear box housing.

NOTE: If the nipple on the upper housing does not face the back of the unit, turn the upper housing counterclockwise until the nipple faces the back of the unit. Do not turn the upper housing more than one full turn.

27. Once the nipple is positioned, turn the knock-off nut clockwise until it contacts the gear box housing.
28. Tap the knock-off nut with a soft hammer to tighten it against the gear box housing.
29. Making sure that the black o-ring and white back-up ring are lubricated and in place, thread the lower housing into the upper housing. Using two wrenches, hold the upper housing at the wrench flats with one wrench and tighten the lower housing with the other.
30. Attach the high-pressure hose to the nipple on the back of the housing and tighten with a wrench. Do not kink the hose.

NOTE: For low rider units, make sure the hose does not touch the cart frame. If it does, reposition the nipple by turning the upper housing until the hose is clear of the frame and the nipple is within 45° of the back of the unit.

31. Making sure that the black o-ring and white back-up ring are lubricated and in place, reassemble the foot valve assembly and thread it into the lower housing. Tighten securely.
32. Thread the siphon tube/siphon set into the foot valve and tighten securely. Make sure to wrap the threads on the down tube/siphon hose adapter with Teflon tape before assembly.
33. Replace the return hose into the clamp on the siphon tube.
34. Place the front cover on the gearbox housing and secure in position using the four front cover screws.

35. Turn on the sprayer by following the procedure in the "Operation" section of this manual and check for leaks.

NOTE: Repacking kit P/N 800-273 is available. For best results use all parts supplied in this kit.

Replacing the Filters

Pump Filter

1. Loosen and remove the filter body by hand.
2. Slip the filter off of the core spring.
3. Inspect the filter. Based on inspection, clean or replace the filter.
4. Inspect the o-ring. Based on inspection, clean or replace the o-ring.
5. Slide the new or cleaned filter over the core spring with the filter spring adapter in place. Push the filter into the center of the filter housing.
6. Slide the filter body over the filter and thread it into the filter housing until secure.

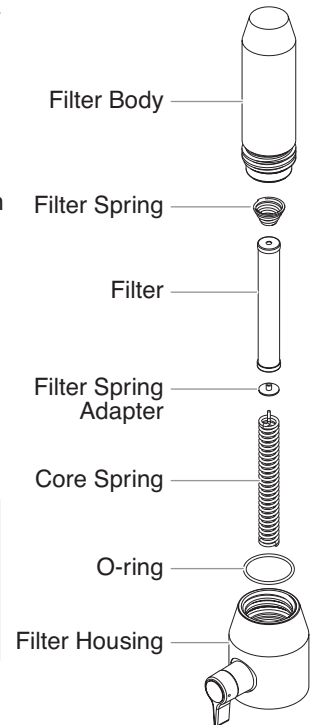

NOTE: The filter body should be hand-tightened, but make sure it is seated fully into the filter housing.

Gun Filter

1. Move the gun trigger lock to the unlocked position.
2. Loosen and remove the handle from the gun body.
3. Turning clockwise, unscrew the filter from the gun body.

NOTE: Left-handed threads require turning the filter clockwise to remove.

4. Turning counterclockwise, screw the new or cleaned filter into the gun body.
5. Make sure the handle seal is in position and thread the handle into the gun body until secure.
6. Move the gun trigger lock to the locked position.

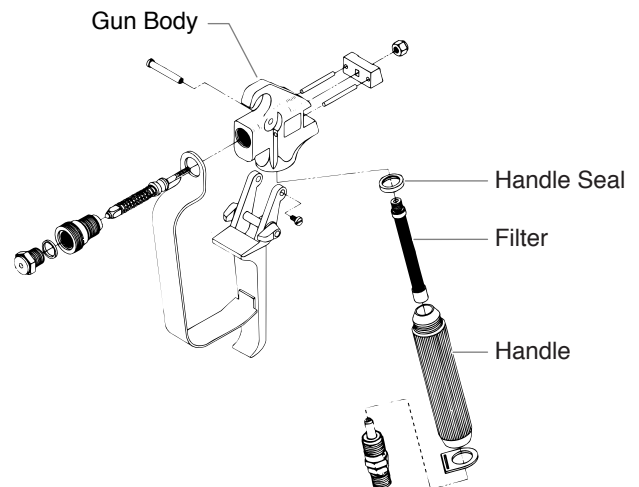

NOTE: For more detail, part number information, and assembly drawings at larger scale, please see the LX -80 Professional Airless Gun Owner's Manual (#313-012).

Troubleshooting

Problem

The unit will not run.

Cause

1. The unit is not plugged in.
2. Tripped breaker.
3. The pressure is set too low (pressure control knob set at minimum setting does not supply power to unit).
4. Faulty or loose wiring.
5. Excessive motor temperature.

Solution

1. Plug the unit in.
2. Reset the breaker.
3. Turn the pressure control knob clockwise to supply power to the unit and increase the pressure setting.
4. Inspect or take to a Titan authorized service center.
5. Allow motor to cool.

The unit will not prime.

1. The PRIME/SPRAY valve is in the SPRAY position.
2. Air leak in the siphon tube/suction set.
3. The pump filter and/or inlet screen is clogged.
4. The siphon tube/suction set is clogged.

1. Rotate the PRIME/SPRAY valve clockwise to the PRIME position.
2. Check the siphon tube/suction set connection and tighten or re-tape the connection with Teflon tape.
3. Remove the pump filter element and clean. Remove the inlet screen and clean.
4. Remove the siphon tube/suction set and clean.

The unit will not build or maintain pressure.

1. The spray tip is worn.
2. The spray tip is too large.
3. The pressure control knob is not set properly.
4. The pump filter, gun filter, or inlet screen is clogged.
5. Material flows from the return hose when the PRIME/SPRAY valve is in the SPRAY position.
6. Air leak in the siphon tube/suction set.
7. There is external fluid leak.
8. There is an internal fluid section leak (packings are worn and/or dirty, valve balls are worn).
9. Worn valve seats
10. Motor powers but fails to rotate (current foldback)

1. Replace the spray tip following the instructions that came with the spray gun.
2. Replace the spray tip with a tip that has a smaller orifice following the instructions that came with the spray gun.
3. Turn the pressure control knob clockwise to increase the pressure setting.
4. Remove the pump filter element and clean. Remove the gun filter and clean. Remove the inlet screen and clean.
5. Clean or replace the PRIME/SPRAY valve.
6. Check the siphon tube/suction set connection and tighten or re-tape the connection with Teflon tape.
7. Check for external leaks at all connections. Tighten connections, if necessary.
8. Clean the valves and service the fluid section following the "Servicing the Fluid Section" procedure in the Maintenance section of this manual.
9. Reverse or replace the valve seats following the "Servicing the Fluid Section" procedure in the Maintenance section of this manual.
10. Take unit to a Titan authorized service center.

Fluid leakage at the upper end of the fluid section.

1. The upper packings are worn.
2. The piston rod is worn.

1. Repack the pump following the "Servicing the Fluid Section" procedure in the Maintenance section of this manual.
2. Replace the piston rod following the "Servicing the Fluid Section" procedure in the Maintenance section of this manual.

Troubleshooting

Problem

Excessive surge at the spray gun.

Cause

1. Wrong type of airless spray hose.
2. The spray tip worn or too large.
3. Excessive pressure.

Solution

1. Replace hose with a minimum of 5m (50') x 10mm (1/4") grounded textile braid airless paint spray hose.
2. Replace the spray tip following the instructions that came with the spray gun.
3. Rotate the pressure control knob counterclockwise to decrease spray pressure.

Poor spray pattern.

-
1. The spray tip is too large for the material being used.
 2. Incorrect pressure setting.
 3. Insufficient fluid delivery.
 4. The material being sprayed is too viscous.

-
1. Replace the spray tip with a new or smaller spray tip following the instructions that came with the spray gun.
 2. Rotate the pressure control knob to adjust the pressure for a proper spray pattern.
 3. Clean all screens and filters.
 4. Add solvent to the material according to the manufacturer's recommendations.

The unit lacks power.

-
1. The pressure adjustment is too low.
 2. Improper voltage supply.

-
1. Rotate the pressure control knob clockwise to increase the pressure setting.
 2. Connect the input voltage to the proper voltage for the unit.

Consignes de sécurité

Ce manuel contient des informations qu'il faut lire et comprendre avant d'utiliser l'appareil. En cas d'accès à une zone comportant l'un des symboles suivants, faire très attention et veiller à respecter les mises en garde.

AVERTISSEMENT

Ce symbole avertit d'un danger potentiel pouvant infliger des blessures graves ou la mort. Il est suivi d'une consigne de sécurité importante.

ATTENTION

Ce symbole avertit d'un risque potentiel pour vous ou pour l'appareil. Il est suivi d'une information importante sur la façon d'éviter les dommages à l'appareil ou de vous protéger des blessures superficielles.

NOTE: Les notes donnent des indications importantes qui doivent être prises très au sérieux.

AVERTISSEMENT

Les appareils sans air comprimé génèrent des pressions de pulvérisation très élevées.



- Ne jamais mettre les doigts, les mains ou une quelconque partie du corps dans le jet de pulvérisation.
- Ne jamais diriger le pistolet vers vous ou vers une autre personne.
- Ne jamais utiliser le pistolet sans sa sécurité.

Attention! Danger de blessure par injection!

En cas de blessure de la peau provoquée par des produits de revêtement ou des solvants, consulter immédiatement un médecin. Communiquer au médecin la nature du produit de revêtement ou du solvant qui a provoqué la blessure.

Les instructions d'utilisation précisent qu'il faut toujours observer les consignes suivantes avant démarrage:

1. Ne pas utiliser d'appareils défectueux.
2. Bloquer le pistolet Wagner avec le cran de sûreté de la gâchette.
3. Veiller à ce que l'appareil soit bien relié à la terre.
4. Contrôler les pressions d'utilisation acceptables.
5. Vérifier qu'aucun raccord ne comporte de fuite.

Les consignes concernant le nettoyage et l'entretien périodique doivent être suivies avec rigueur.

Avant chaque intervention sur l'appareil ou pour chaque arrêt du travail, les règles suivantes doivent être respectées:

1. Libérer la pression dans le pistolet et le flexible.
2. Bloquer le pistolet Wagner avec le cran de sûreté de la gâchette.
3. Arrêter le moteur.

Soyez attentifs à la sécurité!

Toutes les réglementations locales en vigueur doivent être respectées.

Pour garantir la sécurité d'utilisation des systèmes sans air les réglementations de sécurité suivantes doivent être suivies:

1. Pour éviter les dangers, lire attentivement les consignes d'utilisation et suivez les recommandations qui s'y trouvent.

2. N'employez pas des produits de revêtement avec un point d'éclair au-dessous de 21°C (70°F)
3. L'utilisation de cet appareil est interdite dans les ateliers soumis aux règlements contre les explosions.
4. Ne jamais pulvériser près d'une source d'inflammation; par exemple flammes nues, cigarettes (les cigares et les pipes sont également des sources d'inflammation), étincelles, fils chauds, surfaces chaudes, etc...
5. Attention! Risque de blessure par injection!

Ne jamais pointer le pistolet vers vous-mêmes ou une personne quelconque.

Ne jamais mettre les doigts ou la main dans le jet de pulvérisation. Les très hautes pressions de pulvérisation peuvent provoquer des blessures très graves. N'utiliser jamais le pistolet sans sa protection.



Pour le montage ou démontage de la tête de pulvérisation ou lors des pauses dans le travail, le pistolet doit toujours être verrouillé, de façon à ce qu'il ne puisse être activé.

6. Porter un équipement respiratoire pour pulvériser. Un masque de protection doit être fourni à l'opérateur.
De façon à prévenir les maladies professionnelles, les consignes du fabricant de produits, solvants, et agents nettoyants doivent être respectées lors de la préparation, de l'utilisation ou du nettoyage de l'appareil. Des gants et vêtements de protection et, dans certains cas, une crème protectrice sont nécessaire pour protéger la peau.
7. Le pistolet et le flexible haute pression entre l'appareil et le pistolet doivent avoir des spécifications permettant de supporter la pression produite par l'appareil.
La pression de fonctionnement admissible par le flexible, le nom du fabricant et la date de fabrication doivent être indiqués par un marquage d'identification permanent sur le flexible. En outre, il doit être conçu de telle façon que la résistance électrique
8. 8. Dans certaines conditions, la vitesse du flux peut provoquer une charge électrostatique dans l'appareil, ce qui peut provoquer des étincelles ou des flammes de décharge. Il est donc important que l'appareil soit relié en permanence à la terre de l'installation électrique. Le contact doit se faire par l'intermédiaire d'une douille anti-choc mise à la terre conformément aux réglementations.
9. Attention! Observer les précautions suivantes lors de travaux intérieurs ou extérieurs:
Des vapeurs de solvant ne doivent pas être dirigées vers l'appareil. Des vapeurs de solvant ne doivent pas se former autour de l'appareil. Placer l'appareil dans le sens opposé de l'objet à pulvériser. Lors de pulvérisations à l'extérieur, tenir compte de la direction du vent. Lors d'un travail à l'intérieur, prévoir une ventilation suffisante pour assurer l'évacuation des vapeurs de solvant. Une distance minimale de trois mètres doit être respectée entre l'appareil et l'objet à peindre.

10. L'utilisateur doit installer un appareillage d'évacuation conforme aux règlements en vigueur.
11. Les objets à peindre doivent être reliés à la terre.
12. Lors du nettoyage de l'appareil, ne jamais pulvériser de solvant dans un récipient avec une petite ouverture (comme une bonde). La formation d'un mélange explosif air/gaz est probable. Le récipient doit être relié à la terre.
13. Nettoyage de l'appareil.
Ne jamais se servir d'un jet haute pression pour nettoyer l'appareil. En particulier de jamais utiliser un nettoyeur haute pression ou à vapeur. Il y a risque de pénétration d'eau dans l'appareil ce qui peut provoquer un court-circuit.

14. L'action sur la gâchette produit une force de recul sur la main tenant le pistolet.

La force de recul du pistolet est particulièrement élevée avec buse démontée et réglage maximum de la pompe Airless à haute pression. Pour cette raison, en cas de nettoyage sans buse, régler la pompe à la pression minimum.

15. Les fiches doivent toujours être déconnectées des prises d'alimentation électrique lors d'une intervention sur les composants électriques.
16. Seul un électricien agréé doit réparer ou intervenir sur un appareil électrique, même si le travail est décrit dans la notice d'utilisation. Aucune responsabilité ne sera acceptée en cas d'installation électrique incorrecte.
17. Placement de l'appareil sur un sol irrégulier.
L'avant de l'appareil doit être orienté vers le bas, pour que la machine ne puisse glisser loin de l'utilisateur.

DANGER: BLESSURE PAR INJECTION - Un jet de peinture sous haute pression produit par cet appareil peut perforer la peau et les tissus sous-jacents et provoquer des blessures graves pouvant conduire à une amputation.

NE PAS TRAITER UNE BLESSURE PAR INJECTION COMME UNE SIMPLE COUPURE! Une perforation de la peau peut conduire à une amputation. Consulter immédiatement un médecin.

MESURES PREVENTIVES:

- La pression de service maximale du fluide dans l'appareil est de 228 bar (3300PSI).
- NE JAMAIS diriger le pistolet vers une quelconque partie du corps.
- NE JAMAIS mettre une quelconque partie du corps en contact avec le jet de liquide. NE JAMAIS se mettre au contact d'un jet de liquide provenant du flexible d'alimentation en liquide.
- NE JAMAIS placer la main devant le pistolet. Les gants n'offrent pas de protection contre une blessure par injection.
- TOUJOURS verrouiller la gâchette du pistolet, fermer la pompe à liquide et décompresser l'appareil lors de son entretien, du nettoyage de la protection de buse, du remplacement de la buse de pulvérisation ou si l'appareil reste sans surveillance. L'arrêt du moteur n'élimine pas la pression. Le bouton AMORCAGE/PULVERISATION doit être mis sur AMORCAGE pour libérer la pression. Se reporter à la PROCEDURE DE DECOMPRESSION décrite dans ce manuel.
- Pendant la pulvérisation, toujours vérifier que la protection de buse est en place. La protection de buse offre une certaine protection contre les blessures par injection mais sa principale fonction est préventive.
- TOUJOURS retirer la protection de buse avant de rincer ou de nettoyer l'appareil.
- Le flexible d'alimentation en peinture peut fuir par suite d'usure, de vrillage ou de mauvais traitements. Une fuite peut injecter du produit sous la peau. Vérifier le flexible avant chaque utilisation.

AVERTISSEMENT AU MEDECIN:

Une injection sous-cutanée est un accident traumatique. Il est important de traiter la blessure de façon chirurgicale aussitôt que possible. NE PAS RETARDER le traitement pour des recherches de toxicité. La toxicité n'est un risque qu'en cas d'injection de certains enduits directement dans le flux sanguin. Il est conseillé de consulter un chirurgien plasticien ou un chirurgien des mains.

DANGER: EXPLOSION OU INCENDIE – Les vapeurs de solvant ou de peinture sont explosives et inflammables et peuvent causer des dommages matériels et/ou corporels sérieux.

MESURES PREVENTIVES:

- Toujours avoir un extincteur en état de fonctionner à portée de la main.
- Utiliser uniquement des flexibles haute pression conducteurs ou reliés à la terre pour les utilisations sans air comprimé. S'assurer que le pistolet est bien relié à la terre par l'intermédiaire du flexible.
- La pompe doit être connectée à un objet mis à la terre. Utiliser le fil de terre vert pour relier la pompe à un tuyau d'eau, à une poutre métallique ou à une autre surface électriquement mise à la terre.
- Lors du rinçage de l'appareil, utiliser la pression minimale.

DANGER: RISQUE D'EXPLOSION PAR INCOMPATIBILITE DES MATERIAUX – Peuvent être à l'origine de dommages matériels ou corporels sérieux.

MESURES PREVENTIVES:

- Ne pas utiliser d'eau de Javel.
- Ne pas utiliser de solvants aux hydrocarbures halogénés comme le chlorure de méthylène et le trichloroéthane-1-1-1. Ces produits sont incompatibles avec l'aluminium et peuvent provoquer une explosion. En cas de doute sur la compatibilité du produit avec l'aluminium, prendre contact avec votre fournisseur de peinture.

DANGER: GENERALITES – Peut provoquer des dommages matériels ou corporels sérieux.

MESURES PREVENTIVES:

- Cette pompe à haute pression sans air comprimé est conçue pour être utilisée uniquement avec des pièces agréées par le fabricant. Toute utilisation de l'appareil avec des pièces ne répondant pas aux normes techniques et aux dispositifs de sécurité de base du fabricant de la pompe se fera aux risques et périls de l'utilisateur.
- Vérifier, avant toute utilisation, que les flexibles ne présentent pas de coupures, de fuites, de traces d'usure ni de renflement de la gaine, ainsi que des raccords endommagés. Si le flexible a subi l'un des dommages précités, le remplacer immédiatement. Ne jamais réparer un flexible d'alimentation en peinture. Le remplacer par un autre flexible relié à la terre.
- Ne jamais pulvériser quand il y a du vent.
- Porter des lunettes de protection.

Directives de mise à la terre

Cet appareil doit être relié à une terre. En cas de court-circuit, la mise à la terre réduit le risque de choc électrique en fournissant une ligne de fuite au courant électrique. Cet appareil est fourni avec un câble d'alimentation muni d'un fil de terre et d'une fiche appropriée. La fiche doit être reliée à une prise correctement installée et mise à la terre selon les normes et règlements locaux.

DANGER – Une installation inadéquate de la prise de terre peut être la cause d'un choc électrique.

S'il est nécessaire de réparer ou de remplacer le câble ou la fiche, ne pas connecter le fil vert de mise à la terre à l'une des bornes à broches plates. Le fil comportant un isolant vert, avec ou sans lignes jaunes est le fil de terre et doit être connecté à la broche de terre.

Contrôler avec un électricien qualifié ou un technicien que les directives de mise à la terre sont entièrement comprises ou en cas de doute, que le raccordement de l'appareil à la terre est efficace. Ne pas modifier la fiche qui est fournie. Si la fiche ne s'adapte pas à la prise, demander à un électricien qualifié d'installer une prise appropriée.

Precauciones de Seguridad

Este manual contiene información que tiene que leerse y entenderse antes de utilizar el equipo. Cuando se encuentre en una área que tenga uno de los siguientes símbolos, esté muy atento y asegúrese que tiene en cuenta la seguridad.

ADVERTENCIA

Estos símbolos indican un peligro potencial que puede causar graves daños o pérdidas humanas. A continuación se explica información importante para la seguridad.

PRECAUCION

Estos símbolos indican un peligro potencial para usted o para su equipo. A continuación se explica información que puede prevenir daños en el equipo o cómo evitar las causas que provocan daños menores.

NOTA: Las notas dan información importante que tendría que ser considerada con especial atención.

ADVERTENCIA

Las unidades sin aire desarrollan presiones de pulverización extremadamente altas.



- Nunca poner los dedos, las manos ni ningún otro miembro del cuerpo en la boquilla del pulverizador.
- Nunca apuntar la pistola pulverizadora a uno mismo ni a ninguna otra persona.
- Nunca utilizar la pistola pulverizadora sin la protección de seguridad.

¡Atención! ¡Peligro de lesiones por inyección!

En caso de lesiones en la piel causadas por materiales de revestimiento o solventes, consultar a un médico inmediatamente. Informar al médico del tipo de material de revestimiento o agente de limpieza con el que se causó la lesión.

Las instrucciones de empleo señalan que deben observarse siempre los siguientes puntos antes de empezar:

1. No deben utilizarse las unidades averiadas.
2. Asegurar la pistola pulverizadora utilizando el pasador de seguridad en el disparador.
3. Asegurarse de que la unidad está puesta a tierra correctamente.
4. Comprobar las presiones operativas permisibles.
5. Comprobar todas las conexiones para ver si existen fugas.

Deben observarse estrictamente las instrucciones referentes a la limpieza y mantenimiento regular de la unidad.

Antes de realizar ningún trabajo en la unidad o cuando se tome un descanso en el trabajo, deben observarse las siguientes normas:

1. Aliviar la presión de la pistola pulverizadora y de la manguera.
2. Asegurar la pistola pulverizadora utilizando el pasador de seguridad en el disparador.
3. Apagar el motor.

¡Ser precavido!

Deben observarse todas las ordenanzas locales en vigor.

Para asegurar un funcionamiento seguro de los sistemas sin aire deben seguirse las normas de seguridad que se listan a continuación:

1. Para evitar peligros, leer detalladamente las instrucciones de empleo y seguir las instrucciones que se indican en las mismas.
2. No utilice los materiales de revestimiento con un punto de inflamación debajo de 21°C (70°F).
3. Se prohíbe el uso de esta unidad en talleres que estén bajo ordenanzas de prevención de explosiones.
4. Nunca operar cerca de fuentes de combustión, v.gr.: llamas abiertas, cigarrillos, cigarrillos y pipas, chispas, alambres al rojo vivo, superficies calientes, etc.
5. ¡Atención! ¡Riesgo de lesiones por inyección!
Nunca apuntar la pistola pulverizadora a uno mismo ni a otras personas.

Nunca poner los dedos o las manos en la boquilla del pulverizador. Las presiones de pulverización que son muy altas pueden ocasionar lesiones muy graves. Nunca utilizar la pistola pulverizadora sin la protección de seguridad.



Al instalar y extraer la puntera y durante los descansos en el trabajo, la pistola pulverizadora debe estar siempre bloqueada, de forma que no pueda activarse.

6. Usar equipo respiratorio al pulverizar. El operario debe estar provisto con una mascarilla protectora. Para evitar enfermedades profesionales, deben observarse las regulaciones del fabricante con respecto a los materiales, solventes y agentes de limpieza utilizados al preparar, trabajar con y limpiar la unidad. Para proteger la piel es necesario usar ropa protectora, guantes y, en algunos casos, crema protectora de la piel.
7. La pistola pulverizadora y la manguera de alta presión entre la unidad y la pistola pulverizadora debe ser de un estándar suficiente para la presión producida en la unidad.

En la manguera debe indicarse con una marca de identificación permanente la presión operativa permisible para la manguera de alta presión, el fabricante y la fecha de fabricación de la misma. Además, debe estar construida de tal forma que la resistencia eléctrica entre las conexiones a la unidad y la pistola pulverizadora sea igual a o inferior a un megaohmio.

8. En ciertas condiciones la velocidad del caudal puede causar una carga electrostática en la unidad. Esto puede causar chispas o llamas en la descarga. Por lo tanto, es importante que la unidad esté siempre puesta a tierra sobre la instalación eléctrica. El contacto debe realizarse usando un receptáculo a prueba de sacudidas puesto a tierra conforme a las regulaciones.
9. ¡Atención! Observar las siguientes indicaciones al trabajar en el interior y al aire libre:
No deben llevarse gases de solventes a la unidad. No deben formarse gases de solventes cerca de la unidad. Instalar la unidad en el lado opuesto al objeto que se vaya a pulverizar. Cuando se pulverice al aire libre, tener en cuenta la dirección del viento. Al trabajar en el interior, asegurarse de que haya suficiente ventilación para la extracción de los gases de solvente. Debe observarse una distancia mínima de 3 m entre la unidad y el objeto que se esté pulverizando.
10. El usuario debe tener instalado un equipo de extracción conforme a los reglamentos locales.
11. Los objetos que se estén pulverizando deben estar puestos a tierra.
12. Al limpiar la unidad, no pulverizar nunca solventes en un envase que tenga una abertura pequeña (piguera). Puede formarse una mezcla explosiva de gas/aire. El envase debe estar puesto a tierra.

13. Limpieza de la unidad.

Nunca debe utilizarse una boquilla gruesa para pulverizar la unidad. En particular, nunca debe utilizarse un limpiador de alta presión o limpiador a vapor de alta presión. Hay peligro de que el agua penetre en la unidad y cause un cortocircuito.

14. El apriete del disparador ejerce una fuerza de retroceso en la mano, con la que se dirige la pistola de pulverización.

La fuerza de retroceso de la pistola de pulverización es especialmente elevada con la boquilla desmontada y la bomba de alta presión Airless ajustada a presión elevada. Por esa razón, para la limpieza sin boquilla, ajustar la válvula reguladora de presión a la graduación más baja.

15. La clavija principal debe estar siempre desconectada del receptáculo cuando se esté trabajando en los componentes eléctricos.

16. El trabajo o reparaciones en el equipo eléctrico debe ser llevado a cabo solamente por un electricista especializado, incluso si el trabajo se describe en las instrucciones de operación. No se aceptará responsabilidad alguna por una instalación eléctrica incorrecta.

17. Posicionamiento cuando el suelo está desnivelado.

La parte delantera de la unidad debe señalar hacia abajo para que la máquina no pueda resbalar.

PELIGRO: LESIONES POR INYECCION - Un chorro de pintura a alta presión producido por este equipo puede atravesar la piel y los tejidos subyacentes, ocasionando lesiones graves y una posible amputación.

¡NO TRATAR UNA LESION POR INYECCION COMO UN SIMPLE CORTE! La inyección puede conducir a la amputación. Consultar a un médico inmediatamente.

PREVENCION:

- La gama operativa máxima de la bomba es una presión de fluido de 228BAR (3300 PSI).
- NUNCA apuntar la pistola a ninguna parte del cuerpo.
- NUNCA permitir que ninguna parte del cuerpo entre en contacto con el chorro de fluido. NO entrar en contacto con un chorro de fluido creado por una fuga en la manguera de fluido.
- NUNCA poner la mano delante de la pistola. Los guantes no proporcionan protección contra una lesión por inyección.
- Bloquear SIEMPRE el disparador de la pistola, apagar la bomba de fluido y aliviar toda la presión antes de realizar el mantenimiento, limpiar la protección de la puntera, cambiar punteras o al dejar desatendida la pistola. La presión no se aliviará apagando el motor. La perilla de PRIME/SPRAY (CEBADO/PULVERIZACION) debe estar girada a PRIME (CEBADO) para aliviar la presión. Consultar el PROCEDIMIENTO DE ALIVIO DE PRESION que se describe en este manual.
- La protección de la puntera debe estar siempre en su lugar cuando se pulverice. La protección de la puntera ofrece un poco de protección contra las lesiones por inyección, pero principalmente es un dispositivo de advertencia.
- Extraer SIEMPRE la puntera de pulverización antes de enjuagar o limpiar el sistema.
- La manguera de pintura puede desarrollar fugas por desgaste, retorcimiento y abuso. Una fuga puede inyectar material en la piel. Inspeccionar la manguera de pintura antes de cada uso.

NOTA AL MEDICO: La inyección en la piel es una lesión traumática, por ello es importante tratar la lesión quirúrgicamente tan pronto como sea posible. NO retrasar el tratamiento para investigar la toxicidad. La toxicidad está vinculada con algunos revestimientos inyectados directamente en la sangre. Es aconsejable consultar a un cirujano plástico o cirujano de reconstrucción de manos.

PELIGRO: EXPLOSION O INCENDIO - Los gases de solventes y pintura pueden explotar o prender fuego, causando daños a la propiedad y/o lesiones graves.

PREVENCION:

- Se debe tener a mano un equipo de extintor de incendios en buen estado de funcionamiento.
- Usar solamente mangueras de fluidos de alta presión conductivas o puestas a tierra para las aplicaciones sin aire. Asegurarse de que la pistola está puesta a tierra correctamente por medio de las conexiones de la manguera.
- La bomba debe estar conectada a un objeto puesto a tierra. Usar el cable de puesta a tierra verde para conectar la bomba a una tubería de agua, viga de acero u otra superficie puesta a tierra eléctricamente.
- Al enjuagar el equipo, usar la presión más baja posible.

PELIGRO: PELIGRO DE EXPLOSION DEBIDO A MATERIALES INCOMPATIBLES - Puede causar daños a la propiedad o lesiones graves.

PREVENCION:

- No usar lejía.
- No usar solventes de hidrocarburo halogenados tales como cloruro de metileno y tricloroetano - 1,1,1, ya que los mismos no son compatibles con el aluminio y pueden causar una explosión. Si no se está seguro de la compatibilidad de un material con el aluminio, ponerse en contacto con el proveedor del revestimiento.

PELIGRO: GENERAL - Puede causar daños a la propiedad o lesiones graves.

PREVENCION:

- Esta bomba sin aire de alta presión está diseñada para su uso únicamente con piezas autorizadas por el fabricante. Al usar esta bomba con piezas que no cumplan las especificaciones mínimas y dispositivos de seguridad del fabricante de la bomba, el usuario asume todos los riesgos y responsabilidad.
- Antes de cada uso, comprobar todas las mangueras para ver si presentan cortes, fugas, abrasión o abultamientos de la cubierta, así como daños o movimientos de los acopladores. Si se da alguna de estas condiciones, reemplazar la manguera inmediatamente. Nunca reparar una manguera de pintura, reemplazar la misma con otra manguera puesta a tierra.
- Usar gafas protectoras.
- No pulverizar en días con viento.

Instrucciones de puesta a tierra

Este producto debe estar puesto a tierra. En el caso de que ocurra un cortocircuito, la puesta a tierra reduce el riesgo de una sacudida eléctrica proporcionando un cable de escape para la corriente eléctrica. Este producto está equipado con un cordón que tiene un cable de puesta a tierra con una clavija de puesta a tierra apropiada. La clavija de conexión debe estar enchufada en una salida que esté correctamente instalada y puesta a tierra de conformidad con todos los códigos y ordenanzas locales.

PELIGRO — La instalación incorrecta de la clavija de puesta a tierra puede tener como resultado el riesgo de una sacudida eléctrica.

Si es necesario reparar o reemplazar el cordón o la clavija, no conectar el cable de puesta a tierra verde a ninguno de los terminales de cuchilla plana. El cable con insulación que tiene una superficie exterior verde con o sin rayas amarillas es el cable de puesta a tierra y debe estar conectado a la espiga de puesta a tierra.

Verificar con un electricista o técnico de reparaciones especializado si no se entienden por completo las instrucciones de puesta a tierra, o si se tiene dudas de que el producto esté correctamente puesto a tierra. No modificar la clavija que se suministra; si la misma no encaja en la toma de corriente, hacer que un electricista especializado instale la toma de corriente apropiada.

Parts List

Main Assembly

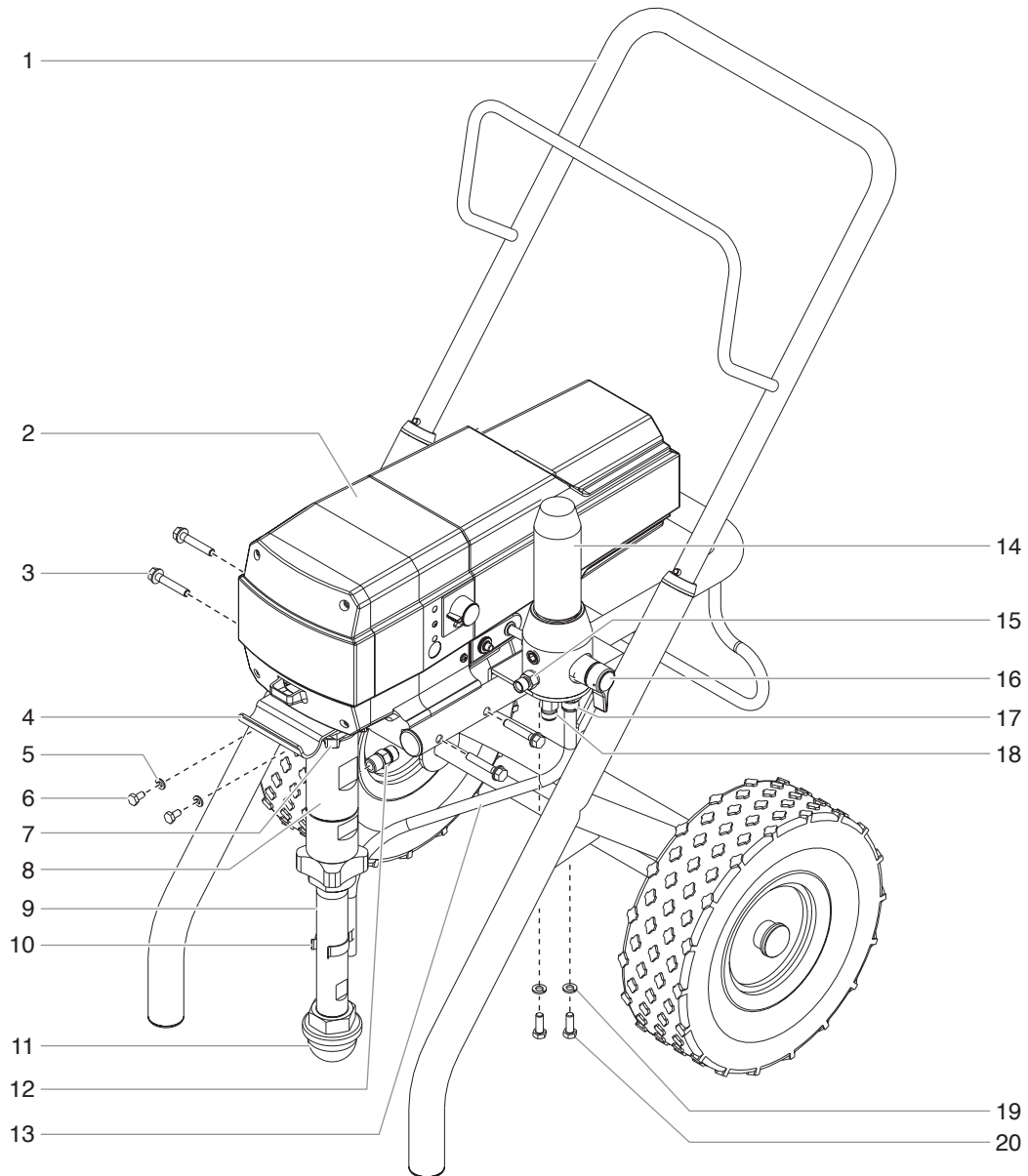

Item	Part #	Description	Quantity	Item	Part #	Description	Quantity
1	800-600	Cart assembly.....	1	13	800-904	Return hose	1
2	-----	Drive assembly	1	14	800-900	Filter assembly.....	1
3	761-178	Screw	4	15	812-003	Outlet fitting.....	1
4	800-324	Pail hook	1	16	800-915	PRIME/SPRAY valve assembly.....	1
5	763-551	Lock washer.....	2	17	800-269	Fitting	1
6	858-625	Screw	2	18	800-267	Fitting (high rider)	1
7	800-328	Knock-off nut.....	1		800-268	Fitting (low rider, not shown)	1
8	800-300	Fluid section assembly	1	19	860-002	Lock washer.....	2
9	451-241	Siphon tube.....	1	20	860-535	Screw	2
10	730-334	Hose clamp	1	21	800-266	Hose (not shown)	1
11	710-046	Inlet screen	1	22	818-002	Elbow, 90°, return hose (low rider, not shown)	1
12	800-268	Fitting	1				

Drive Assembly

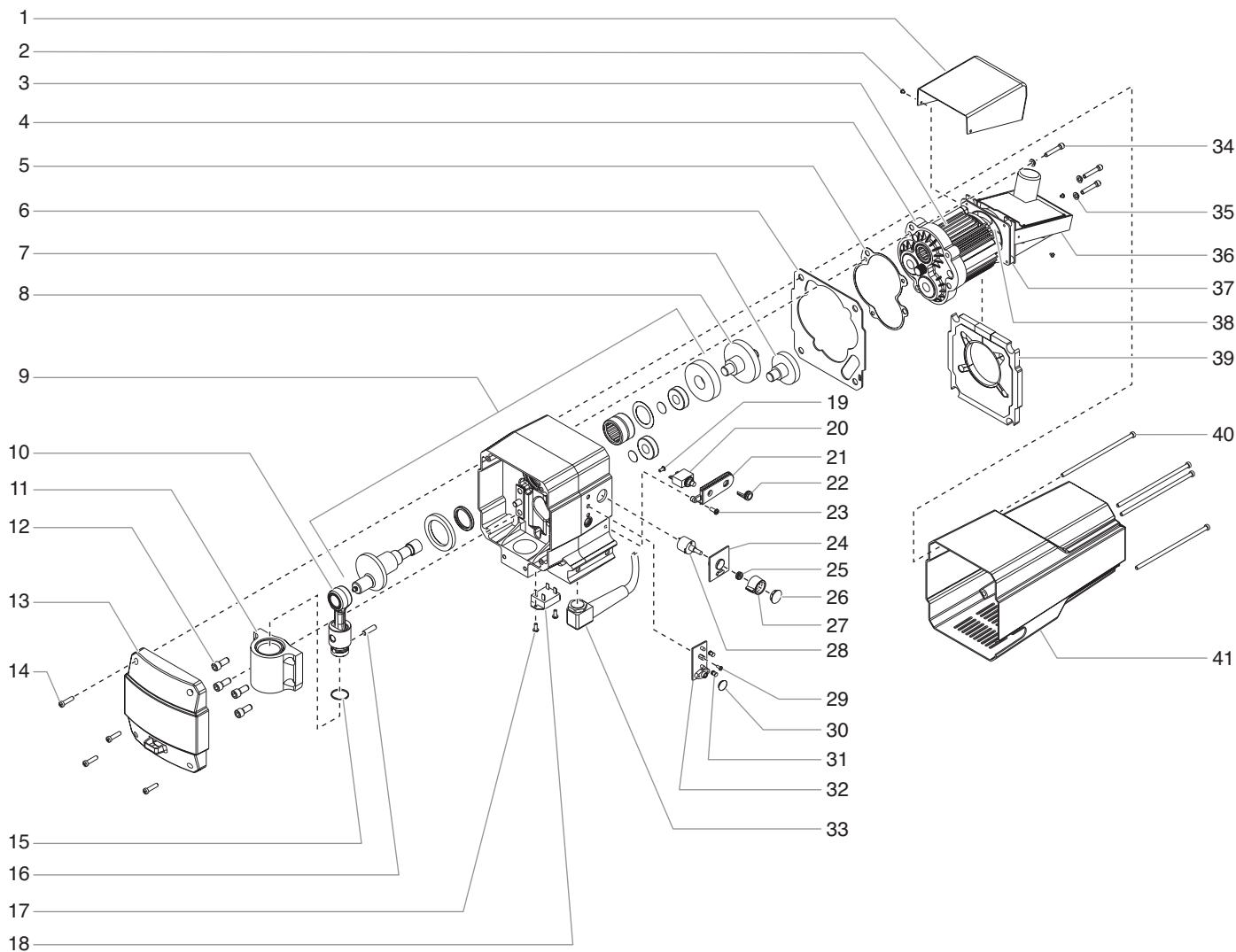

Item	Part #	Description	Quantity
1	800-078	Electronic cover	1
2	800-205	Screw	3
3	800-224	Motor assembly, 1.1 HP	1
4	800-256	Front end bell assembly	1
5	800-525	Housing gasket	1
6	800-541	Shroud gasket.....	1
7	800-261	1st stage gear assembly.....	1
8	800-262	2nd stage gear assembly	1
9	800-259	Front gearbox assembly	1
10	800-510	Slider assembly	1
11	800-253	Slider housing.....	1
12	700-283	Screw	4
13	800-265	Front cover with label	1
14	800-284	Screw	4
15	800-382	Retaining ring.....	1
16	800-753	Connecting pin.....	1
17	800-206	Screw	2
18	800-376	Relay.....	1
19	704-229	Screw	1
20	800-389	Circuit breaker	1
21	800-075	Mounting plate	1
22	800-077	Grommet.....	1

Item	Part #	Description	Quantity
23	800-076	Screw	1
24	800-274	Potentiometer mounting plate.....	1
25	700-176	Nut	1
26	700-175	Cap	1
27	700-159	Pressure control knob.....	1
28	800-277	Potentiometer	1
29	800-203	Screw	1
30	704-281	Port plug	1
31	800-043	LED cover	2
32	800-278	Indicator lights assembly	1
33	800-096	Power cord w/strain relief (high rider).....	1
	800-093	Power cord w/strain relief (low rider)	1
34	700-287	Screw	3
35	763-551	Lock washer.....	3
36	800-223	Electronic control assembly.....	1
37	800-215	Fan shroud.....	1
38	800-294	Fan assembly	1
39	800-435	Baffle assembly	1
40	800-283	Screw	4
41	800-254	Motor shroud w/labels	1
42	800-366	Wire cover, 7" (not shown)	1
43	800-368	Wire assembly (not shown)	1

NOTE: All electrical work should be performed by a Titan authorized service center.

Fluid Section Assembly (P/N 800-300)

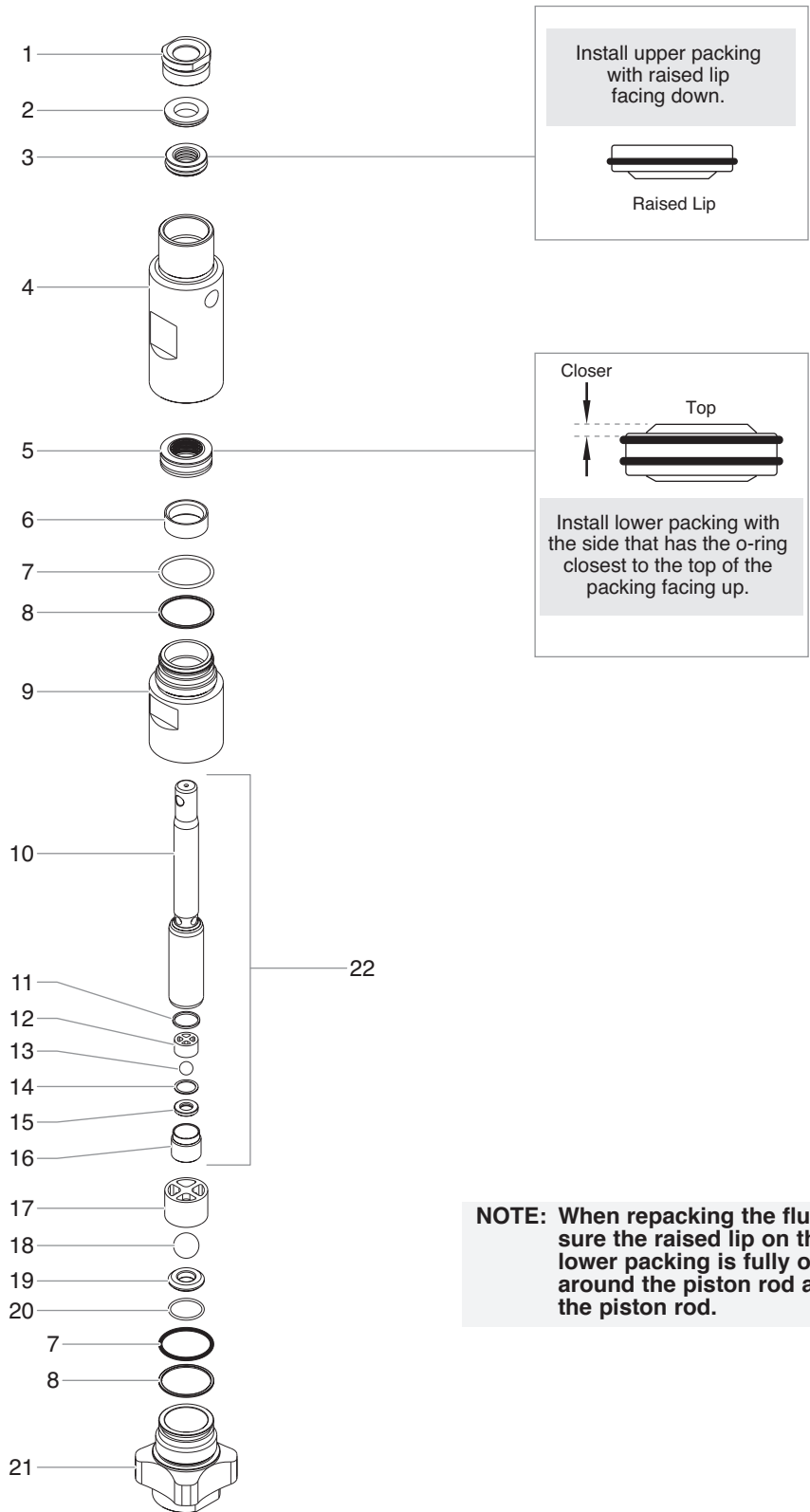

NOTE: When repacking the fluid section, make sure the raised lip on the bottom of the lower packing is fully outside the packing around the piston rod after insertion of the piston rod.

Item	Part #	Description	Quantity
1	800-325	Upper seal retainer	1
2	800-327	Spacer	1
3	800-248	Upper packing assembly	1
4	800-351	Upper housing	1
5	800-250	Lower packing assembly	1
6	800-354	Wear ring	1
7	800-332	O-ring, black	2
8	800-333	Back-up ring, white	2
9	800-352	Lower housing	1
10	800-246	Piston rod.....	1
11	800-348	Outlet valve seal.....	1
12	800-244	Outlet valve cage.....	1
13	800-247	Outlet valve ball.....	1

Item	Part #	Description	Quantity
14	800-245	Washer, nylon	1
15	800-243	Outlet valve seat.....	1
16	800-336	Outlet valve retainer	1
17	800-322	Foot valve cage	1
18	800-242	Foot valve ball	1
19	800-241	Foot valve seat	1
20	762-058	O-ring.....	1
21	800-305	Foot valve housing	1
22	800-365	Piston assembly (includes items 10–16)....	1
	800-359	Lower packing insertion tool	
	800-273	Repacking kit (includes items 2, 3, 5–8, 11, 13, 14, 18, 20, and tool)	

High Rider Cart (P/N 800-600)

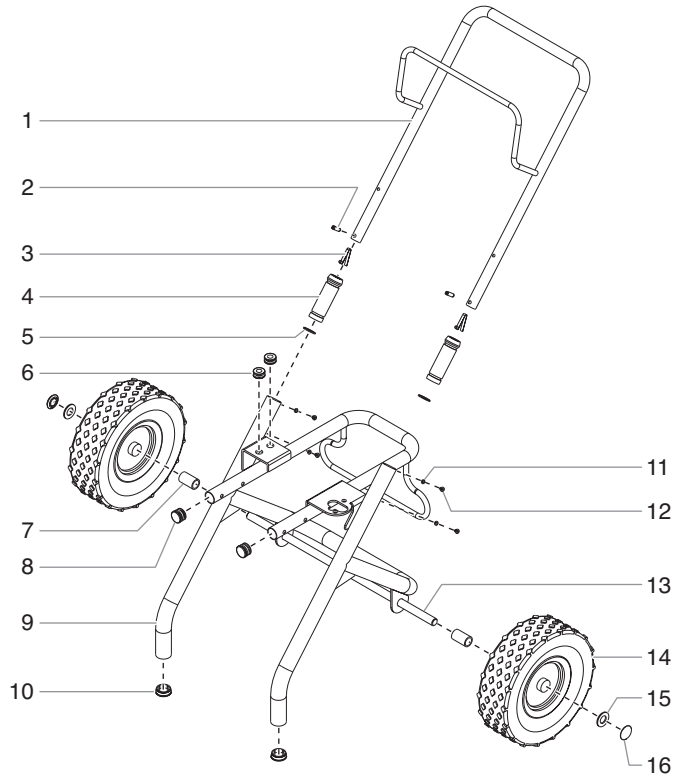

Item	Part #	Description	Quantity
1	800-280	Handle (includes items 2–5, 11, and 12)	1
2	590-508	Roll pin.....	2
3	590-507	Snap button	2
4	590-504	Sleeve.....	2
5	590-506	Washer.....	2
6	800-036	Grommet.....	2
7	800-011	Spacer	2
8	710-199	Plug.....	2
9	800-279	Cart (includes items 8 and 10)	1
10	335-018	Plug.....	2
11	856-002	Washer.....	4
12	856-921	Screw.....	4
13	800-007	Axle.....	1
14	670-109	Wheel.....	2
15	870-004	Washer.....	2
16	800-019	Cap.....	2

Filter Assembly (P/N 800-900)

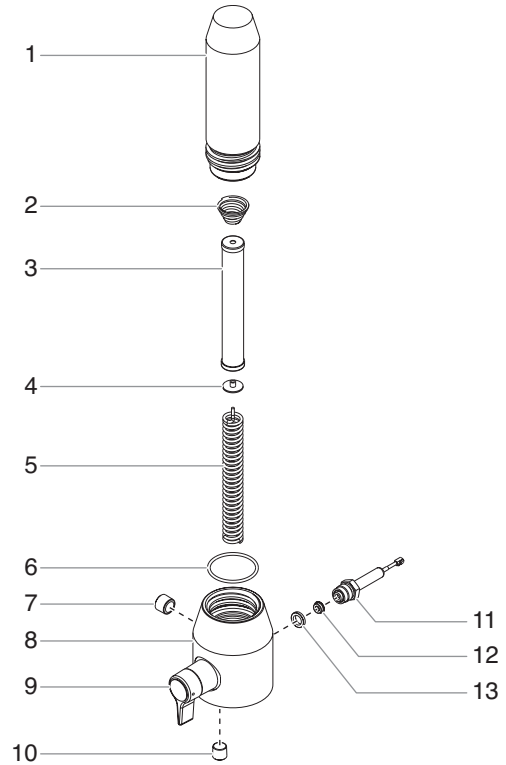

Item	Part #	Description	Quantity
1	800-905	Filter body	1
2	800-252	Filter spring	1
3	730-067	Filter, 60 mesh	1
4	702-251	Filter spring adapter.....	1
5	757-105	Core spring	1
6	800-906	O-ring, Teflon	1
7	800-908	Plug, 3/8"	1
8	800-918	Filter housing	1
9	800-915	PRIME/SPRAY valve assembly	1
10	800-907	Plug, 1/4"	1
11	800-448	Transducer	1
12	800-916	Transducer cap.....	1
13	800-911	Inner seal.....	1
	800-449	Transducer assembly (includes items 11–13)	

Siphon Set (low rider)

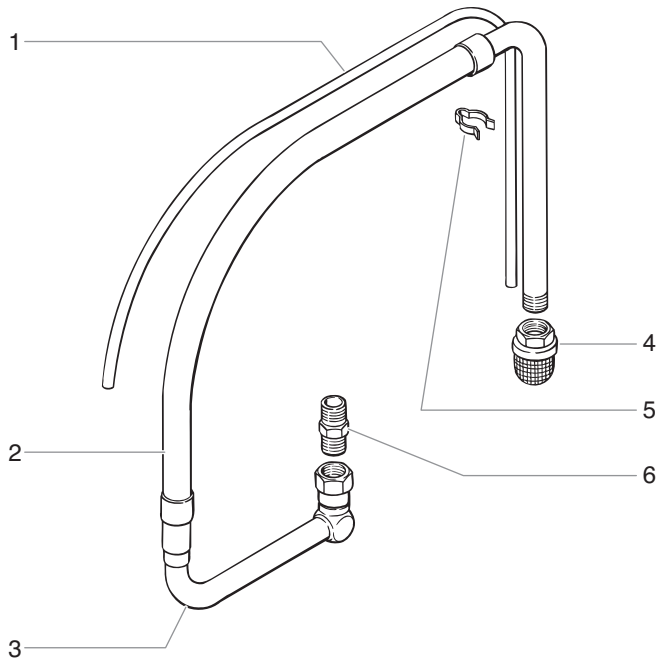

Item	Part #	Description	Quantity
1	800-903	Return hose	1
2	710-203	Siphon hose.....	1
3	710-195	Swivel	1
4	710-046	Inlet screen	1
5	730-334	Clamp	1
6	710-081	Siphon hose adapter	1
7	700-742	Tie wrap (not shown)	3
	710-204	Siphon hose assembly (includes items 2–6)	1

Labels

Part #	Description
313-1651	840i logo label
313-1673	Warning label (injection/explosion)
313-1847	Shock hazard label
313-1658	“Press to Reset” label
313-1848	Pressure control knob label
313-1867	Indicator lights label
313-1652	“Titan” front label
313-1906	Infinity logo label

Low Rider Cart (P/N 800-590)

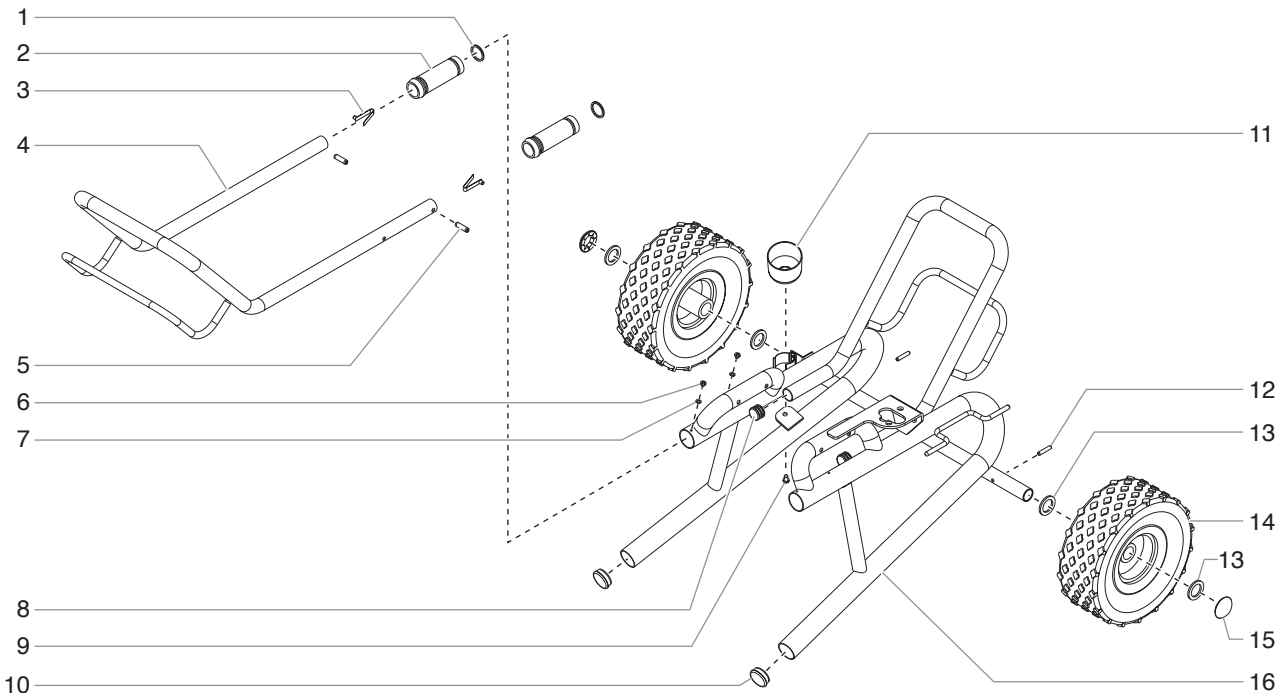

Item	Part #	Description	Quantity	Item	Part #	Description	Quantity
1	590-506	Washer.....	2	9	704-188	Screw	1
2	590-504	Sleeve.....	2	10	335-018	Plug.....	2
3	590-507	Snap button	2	11	700-1041	Drip cup	1
4	800-113	Handle assembly (includes items 1–3 and 5–7)	1	12	704-291	Roll pin.....	2
5	590-508	Roll pin.....	2	13	704-354	Wheel spacer.....	4
6	856-921	Screw.....	4	14	800-593	Wheel.....	2
7	856-002	Washer.....	4	15	704-355	Cap	2
8	700-674	Plug.....	2	16	800-112	Cart weldment (includes items 8 and 10) ...	1

PRIME/SPRAY Valve Assembly (P/N 800-915)

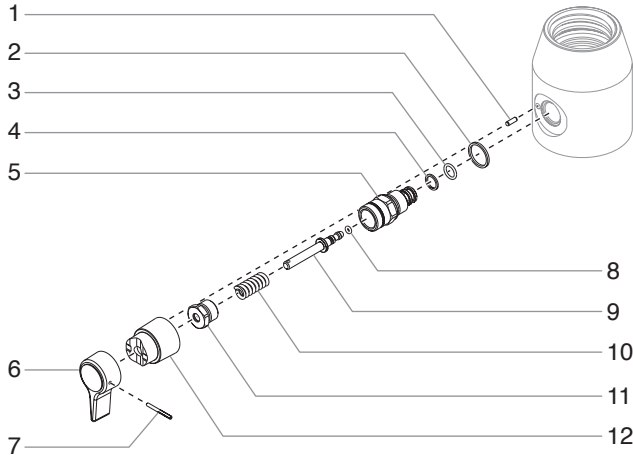

Item	Part #	Description	Quantity
1	700-823	Dowel pin	1
2	700-537	Gasket	1
3	222-012	O-ring, Teflon	1
4	221-012	O-ring, Viton	1
5	800-924	Valve housing	1
6	700-697	Valve handle	1
7	700-759	Groove pin	1
8	700-721	O-ring, Viton	1
9	700-250	Valve stem	1
10	800-926	Spring	1
11	700-248	Valve retainer	1
12	700-251	Cam base	1

NOTE: When using "HOT" solvents, replace Viton o-ring (item 8) with optional Teflon o-ring (700-897). Install with o-ring tool (700-890).

Accessories

Airless Tip Selection

Tips are selected by the orifice size and fan width. The proper selection is determined by the fan width required for a specific job and by the orifice size that will supply the desired amount of fluid and accomplish proper atomization.

For light viscosity fluids, smaller orifice tips generally are desired. For heavier viscosity materials, larger orifice tips are preferred. Please refer to the chart below.

NOTE: Do not exceed the sprayer's recommended maximum tip size.

The following chart indicates the most common sizes and the appropriate materials to be sprayed.

Tip Size	Spray Material	Filter Type
.011 — .013	Lacquers and stains	100 mesh filter
.015 — .019	Oil and latex	60 mesh filter
.021 — .026	Heavy bodied latex and blockfillers	30 mesh filter

Fan widths measuring 8" to 12" (20 to 30 cm) are preferred because they offer more control while spraying and are less likely to plug.

Liquid Shield Plus

Cleans and protects spray systems against rust, corrosion and premature wear.

Part No.	Description
314-483	4 ounce bottle
314-482	1 quart bottle



Piston Lube

Specially formulated to prevent materials from adhering to the piston rod, which becomes abrasive to the upper seals. Piston Lube will break down any material that may accumulate in the oil cup and keep it from drying.

Part No.	Description
314-481	4 ounce bottle
314-480	8 ounce bottle



Miscellaneous

Part No.	Description
490-012	Hose coupling, 1/4" x 1/4"
730-397	High pressure fluid Gauge
314-171	Lubriplate, 14 ounce individual
314-172	Lubriplate, 6 lb. can
700-1037	Electrostatic discharge (ESD) wrist strap
700-897	O-ring, Teflon
700-890	O-ring tool

Electrical Schematic

NOTE: All electrical work should be performed by a Titan authorized service center.

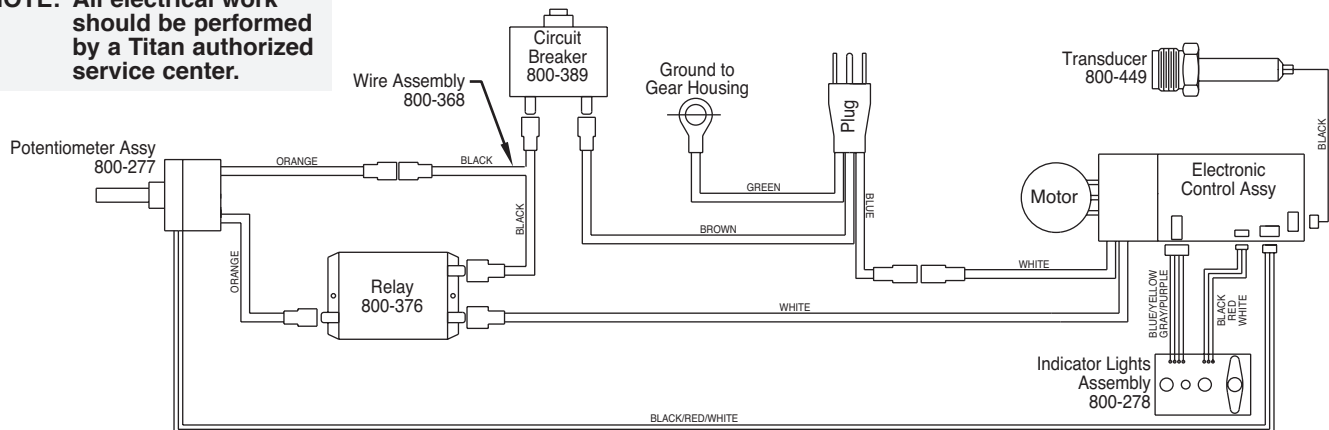

Warranty

Titan Tool, Inc., ("Titan") warrants that at the time of delivery to the original purchaser for use ("End User"), the equipment covered by this warranty is free from defects in material and workmanship. Titan's obligation under this warranty is limited to replacing or repairing without charge those parts which, to Titan's reasonable satisfaction, are shown to be defective within twenty-five (25) months after sale to the End User. This warranty applies only when the unit is installed and operated in accordance with the recommendations and instructions of Titan.

This warranty does not apply in the case of damage or wear caused by abrasion, corrosion or misuse, negligence, accident, faulty installation, substitution of non-Titan component parts, or tampering with the unit in a manner to impair normal operation.

Defective parts are to be returned to an authorized Titan sales/service outlet. All transportation charges, including return to the factory, if necessary, are to be borne and prepaid by the End User. Repaired or replaced equipment will be returned to the End User transportation prepaid.

THERE IS NO OTHER EXPRESS WARRANTY. TITAN HEREBY DISCLAIMS ANY AND ALL IMPLIED WARRANTIES INCLUDING, BUT NOT LIMITED TO, THOSE OF MERCHANTABILITY AND FITNESS FOR A PARTICULAR PURPOSE, TO THE EXTENT PERMITTED BY LAW. THE DURATION OF ANY IMPLIED WARRANTIES WHICH CANNOT BE DISCLAIMED IS LIMITED TO THE TIME PERIOD SPECIFIED IN THE EXPRESS WARRANTY. IN NO CASE SHALL TITAN LIABILITY EXCEED THE AMOUNT OF THE PURCHASE PRICE. LIABILITY FOR CONSEQUENTIAL, INCIDENTAL OR SPECIAL DAMAGES UNDER ANY AND ALL WARRANTIES IS EXCLUDED TO THE EXTENT PERMITTED BY LAW.

TITAN MAKES NO WARRANTY AND DISCLAIMS ALL IMPLIED WARRANTIES OF MERCHANTABILITY AND FITNESS FOR A PARTICULAR PURPOSE WITH RESPECT TO ACCESSORIES, EQUIPMENT, MATERIALS OR COMPONENTS SOLD BUT NOT MANUFACTURED BY TITAN. THOSE ITEMS SOLD, BUT NOT MANUFACTURED BY TITAN (SUCH AS GAS ENGINES, SWITCHES, HOSES, ETC.) ARE SUBJECT TO THE WARRANTY, IF ANY, OF THEIR MANUFACTURER. TITAN WILL PROVIDE THE PURCHASER WITH REASONABLE ASSISTANCE IN MAKING ANY CLAIM FOR BREACH OF THESE WARRANTIES.

Material Safety Data Sheets (MSDS) are available on Titan's website or by calling Customer Service.



United States Sales & Service

1-800-526-5362

Fax 1-800-528-4826

556 Commerce Street
Franklin Lakes, NJ 07417

www.titantool.com

Canadian Branch

1-800-565-8665

Fax 1-905-856-8496

200 Trowers Road, Unit 7B
Woodbridge, Ontario L4L 5Z8

International

1-201-337-1240

Fax 1-201-405-7449

556 Commerce Street
Franklin Lakes, NJ 07417 USA